

CL..

... the continuously rotating
Compact-Pneumatic-Torque-Wrenches



CLS



CLS2



CLD



CLV



alkitronic®

alki
TECHNIK
GmbH

alkitronic® Compact-Pneumatic-Torque-Wrench **CLS / CLS2 / CLD**

- ✓ Compact-Pneumatic-Torque Tool for continuously rotating loosening or tightening of bolted connections
- ✓ **Heavy-duty gear box** - highly developed and proven
- ✓ Pneumatic-drive - **reliable** and **robust**
- ✓ Mechanical selection switch for **power/run-down gear** (CLS-2 gear)
- ✓ Upon request: Execution with locking flip switch or continuous operation for CW-/CCW direction
- ✓ Environmentally positive because of its **low noise level** (optional)
- ✓ Torque setting according to torque flow chart

Optimal applications for areas with air supply systems and in high explosion-risk areas.

alkitronic® **CLS / CLS2**

Principle of construction:

Rigid connection between operating element and power gearing!

Through the tothing on the reaction support (DMA) and the external tothing of the tool, the position of your Compact-Pneumatic-Torque Wrench can be changed in approx. 10-15 degrees by each step.

- ✓ **alkitronic® CLS**
The ideal series for low output ranges, from 60 Nm up to 3500 Nm.
- ✓ **alkitronic® CLS2**
The powerful universal tools for screw connections where flexibility and high output power are required. Mechanical changeover from **run down gear** to **power gear**. You will reach torque ranges from 120 Nm up to 48000 Nm.



alkitronic® **CLD**

Principle of construction:

Free joint execution!

After fixing your reaction support (DMA) you will be able to reach any position you may require (rotatable 360 degrees)

- ✓ The ideal torque wrenches with high comfort for operating in narrow spaces - torque ranges from 150 Nm up to 11200 Nm.



Technical Informations **alkitronic**® CLS / CLS2 / CLD

alkitronic®-Compact-Pneumatic-Torque Wrenches for a non-pullating operating at site.

A Standard version noise level = 78 dB(A)

B Special version (optional)

The noise level will amount 66-78 dB(A) according to the number of used sound absorbers and an air pressure of 6 bar.

By using sound absorbers take notice that the torque values of the flow chart will not be the same. Approx. 10% deviation of the stated torque values is possible. Flow chart values have to be corrected correspondingly.

alkitronic®-Compact-Pneumatic-Torque Wrenches with lower noise level are controlled and approved by the German TÜV PRODUCT SERVICE.

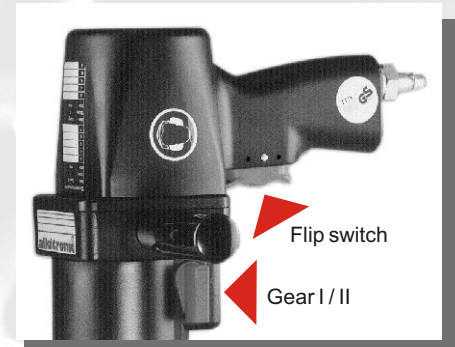
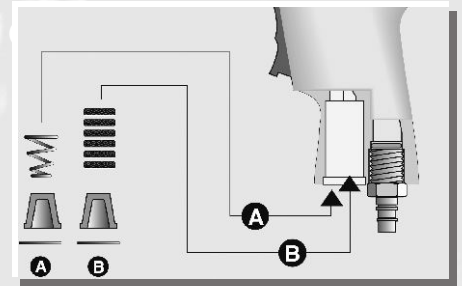

Standard version:
Flip switch (CW-/CCW direction), changeover switch for run down gear/power gear (CLS2)

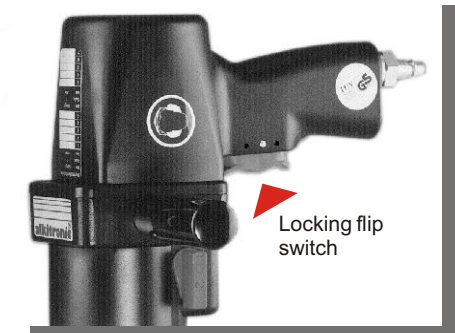

Special execution with locking flip switch for CW-/CCW direction (continuous operation). Positions flip switch: R - ● - L

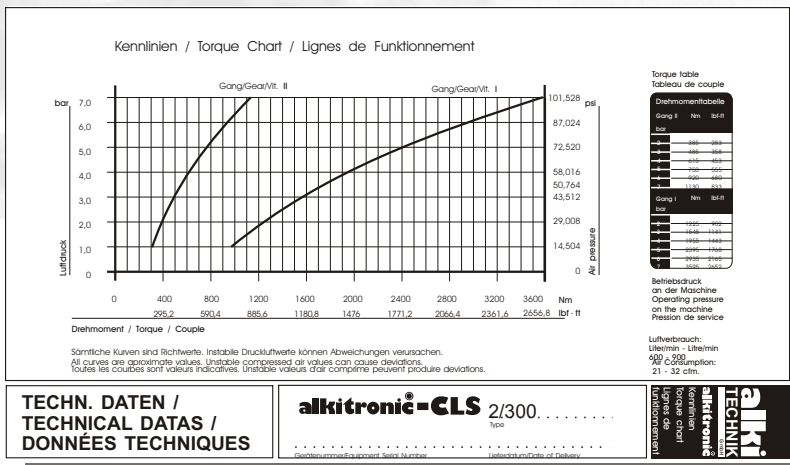

Example:
of a **torque flow chart** stating the torque values reached by the corresponding air pressure.

alkitronic® CLV

- ✓ Small, compact and powerful
- ✓ CW-/CCW operation via the remote control FBL
- ✓ The ideal **principle of construction for Remote-Systems** (the optimal solution for the simultaneous use of several torque tools)
- ✓ Optimal application for **series-assembly** and **half-automatic operation**
- ✓ Environmentally positive because of its **low noise level**
- ✓ For continuously rotating to loosen or tighten bolted connections - **continuous operation and emergency operation** are possible
- ✓ **Heavy duty gear box** - highly developed and proven
- ✓ Pneumatic-drive - reliable and robust
- ✓ Torque flow chart with torque settings

Optimal operating in air supply networks and even in high explosion-risk areas.



Technical Informations **alkitronic® CLV**

alkitronic® -FBL-DUO

Remote control

for 2 CLV-tools (principle description)

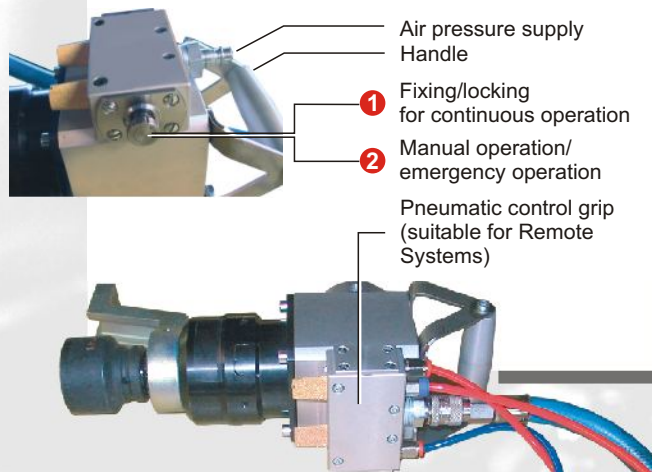
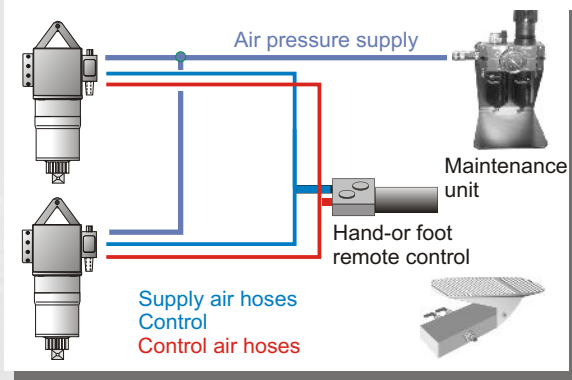

The perfect solution for a constant and simultaneous operation.

Version **FBL Quattro** (4 CLV-torque tool) upon request

Technical Data **alkitronic® CLV**

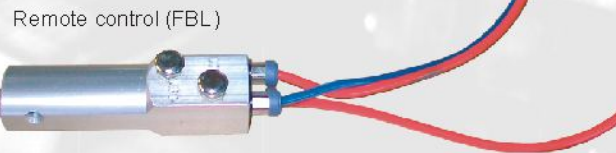
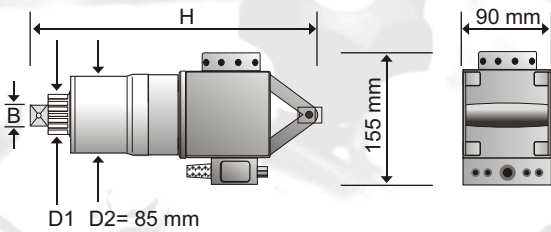

Remote control (FBL)

Series CLS	Type	CLV 15*	CLV 25	CLV 35	CLV 45	CLV 75	CLV 95	CLV 135	CLV 175	CLV 255	CLV 315
Performance **	Nm	60-220	95-280	135-390	165-485	305-895	365-1080	495-1450	645-1900	910-2670	1180-3460
Square drive	B	1/2" / 3/4"	1/2" / 3/4"	3/4"	3/4"	3/4"	3/4"	1"	1"	1"	1"
Diameter D ₁ **	mm	41	41	41	41	41	41	54	54	54	54
Height (H)	mm	296	296	296	296	318	318	320	340	372	372
Weight without support**	kg	5,8	5,8	6,2	6,2	6,8	6,8	6,8	6,8	7,4	7,4
Idling speed **	rm ⁻¹	60	38	34	27	19	13	9	7	6	4
Prices	EUR										

* Output profile: quick rotating tool
 Attention: Take care to secure and stable the reaction support.
 **approximate values

General Informations **alkitronic® CLV**

alkitronic® - CLV Sound absorption and ventilator system

For further informations contact us!

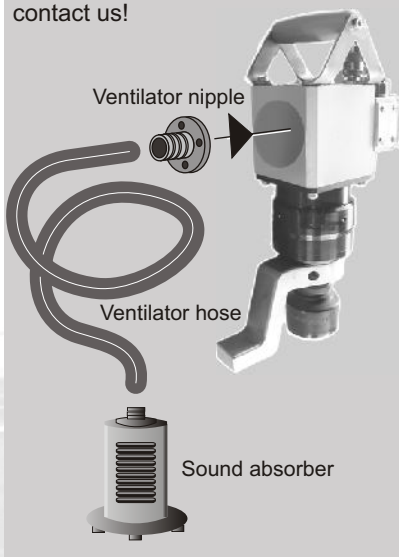

alkitronic® - CLV Ventilator system High-quality external sound absorption for **CLV-Torque wrenches**

Technical Informations:

Optimum sound absorption depends on:

- how the ventilated air is drawn off (ventilator hose)
- the length and the cross section of the ventilator hose
- the construction of the sound absorber

The noise level is considerably influenced by these factors.

alkitronic® - CLV Ventilator system

Advantages

- low noise level
- no whirl of air when operating
- operation in ventilation free surroundings

Technical Details:

Torque regulation of all CLV tools via air supply and a manostat of the maintenance unit. Torque exactness depends on a stable air network. An air pressure of 2 -7 bars at an air volume of approx. 10-15 l/sec ensures optimal operating

Accessories:

Maintenance unit complete with filter, regulator, lubricator as well as spiral hose of 5 meters length including couplings. In order to maximise operational safety and the lifetime of the motor, the pressurized air should be fed by means of a lubricator with a fine oil spray.



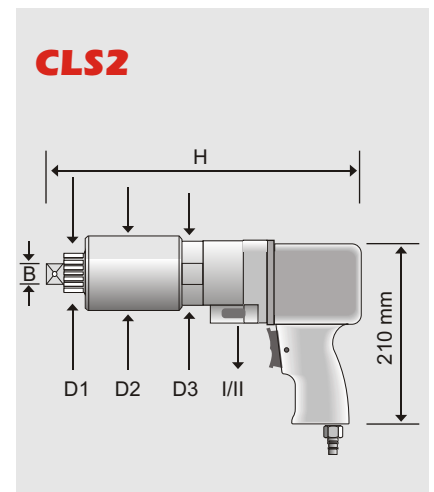
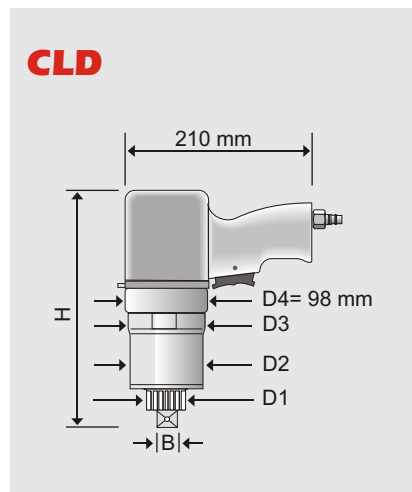
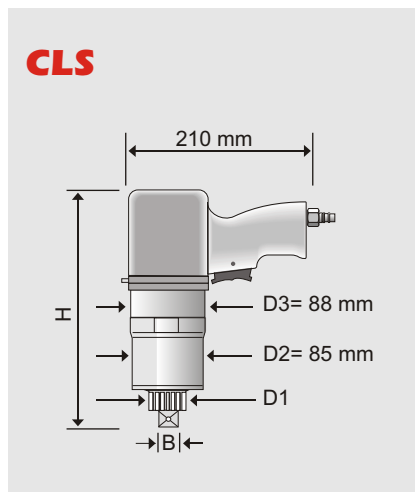

alkitronic® CLS

Series CLS	Type	CLS 15*	CLS 25	CLS 35	CLS 45	CLS 75	CLS 95	CLS 135	CLS 175	CLS 255	CLS 315
Performance **	Nm	60-220	95-280	135-390	165-485	305-895	365-1080	495-1450	645-1900	910-2670	1180-3460
Square drive	B	1/2" / 3/4"	1/2" / 3/4"	3/4"	3/4"	3/4"	3/4"	1"	1"	1"	1"
Diameter D ₁ ***	mm	41	41	41	41	41	41	54	54	54	54
Height (H)	mm	255	255	255	255	277	277	300	300	330	330
Weight without support ***	kg	6	6,5	6,5	6,5	7,5	7,5	8	8	9	9
Idling speed ***	rm ⁻¹	60	38	34	27	19	13	9	7	6	4
Prices	EUR										

*Output profile: quick rotating tool.

Attention: take care to secure and stable the reaction support before operating!

alkitronic® CLD

Series CLD	Type	CLD 55	CLD 85	CLD 105	CLD 125	CLD 155	CLD 255	CLD 280	CLD 380	CLD 580	CLD 780	CLD 980
Performance **	Nm	165-485	305-895	365-1080	450-1315	590-1730	910-2670	1180-3460	1490-4380	2080-6115	3265-9595	3810-11195
Square drive	B	3/4"	3/4"/1"	1"	1"	1"	1"	1"	1 1/2"	1 1/2"	1 1/2"	1 1/2"
Diameter D ₁ ***	mm	41	41/54	54	54	54	54	54	72	72	72	91
Diameter D ₂	mm	85	85	85	85	85	85	85	98	123	148	173
Diameter D ₃	mm	88	88	88	88	88	88	88	98	123	148	173
Height (H)	mm	280	300	300	300	300	300	300	320	350	350	370
Weight without support ***	kg	7	8,5	8,5	8,5	8,5	9	9	12	16	19	25
Idling speed ***	rm ⁻¹	48	25	15	12	10	8	6,5	4	2,5	1	0,5
Prices	EUR											

alkitronic® CLS2

Series CLS2	Type	CLS2/100	CLS2/150	CLS2/300	CLS2/400	CLS2/600	CLS2/800	CLS2/1000	CLS2/1700	CLS2/3400	CLS2/4800
Performance 2 nd gear **	Nm	120-355	170-505	385-1130	540-1585	840-2470	1010-2965	1175-3455	1600-4800	3300-9700	4700-13900
Performance 1 st gear **	Nm	380-1125	550-1615	1225-3595	1720-5055	2675-7865	3210-9435	3745-11010	5800-17000	11500-34000	16000-48600
Square drive	B	3/4"/1"	1	1"	1 1/2"	1 1/2"	1 1/2"	1 1/2"	2 1/2"	2 1/2"	2 1/2"
Diameter D ₁ ***	mm	41/54	54	54	72	72	72	91	SW 120	SW 120	SW 120
Diameter D ₂	mm	85	85	85	98	123	148	173	275	275	275
Diameter D ₃	mm	88	88	88	98	123	148	173	275	275	275
Height (H)	mm	330	330	360	380	410	410	430	570	570	570
Weight without support ***	kg	7	7,5	9	11	15	20	24	60	60	60
Idling speed 2 nd gear ***	rm ⁻¹	36	21	15	9	6	5	4	1	0,8	0,6
Idling speed 1 st gear ***	rm ⁻¹	12	7	5	3	2	1,5	1	0,5	0,4	0,3
Prices	EUR										

** Torque ranges according to enclosed flow torque chart by an air pressure of 2-7 bar. At maximum load, please note that there is an available reserve of approx. 20 % for possibly increased loosening torques. Approximate values.

*** approximate values

Technical details are subject to be changed



EF-SG

Product range:



EFW

alkitronic®

- **Continuously rotating screwing systems:**
Drive manual, electric and pneumatic
- **Gearing technic:**
Central gearing, tangential gearing, radial gearing
- **QMS:**
Quality-Management for Screwed Joints



EFC

BESTMA®

- **Hydraulic torque systems:**
Drive manual, electric and pneumatic
- **Inspection works**



EFCR

alkitronic®
torque power - worldwide

alkitronic®