



PARTS CATALOGUE

FZ1-S (3C3A) EUROPE, SOUTH AFRICA

FZ1-S (3C3B) EUROPE

FZ1-SW (3C3C) AUSTRALIA

FZ1-S/FZ1-SW
PARTS CATALOGUE
©2006 by Yamaha Motor Co., Ltd.
1st edition, October 2006
All rights reserved.
Any reprinting or unauthorized use
without the written permission of
Yamaha Motor Co., Ltd.
is expressly prohibited.
Printed in Japan.

A3

FOREWORD

This Parts Catalogue is related to the parts for the model(s) on the cover page. When you are ordering replacement parts, please refer to this Parts Catalogue and quote both part numbers and part names correctly.

1. Modifications or additions which have been made after the issue of the Parts Catalogue will be announced in the Parts News.

It is advisable that you make the necessary corrections to the Parts Catalogue according to the Parts News.

2. Abbreviations

The following abbreviations are used in this Parts Catalogue.

“UR” Use specified parts number.

“UN” Use as many as needed.

“AP” Alternate Parts

“LM” Locally Made (Parts need to be ordered locally)

“F#” Frame No. (Applicable machine No.)

“O/S” Over Size

3. The number of components for assembly

- Parts, which are to be supplied in an assembly, are listed with a dot (.) in front of the part name as shown below.
- The numeral appearing to the right of each component part indicates the quantity of parts for each assembly unit.

PART NO.	DESCRIPTION	Q'TY	REMARKS
2F5-83310-60	FRONT FLASHER LIGHT ASSY	2	
115-83311-60	.BULB (6V-18W)	1	

4. Applicable colours of graphics are represented in the “REMARKS” as shown below.

PART NO.	DESCRIPTION	Q'TY	REMARKS
2N4-24110-00-X5	FUEL TANK COMP.	2	MXR
3J1-24240-10	.GRAPHIC, FUEL TANK	1	FOR MXR

5. Note that the illustrations for reference in finding parts numbers are not to be used for assembling. When assembling, please use the applicable service manual.

6. The asterisk (*) before a reference number indicates modified items after the first edition.

FOREWORD

7. Applicable Serial No.

Engine Serial No.

Frame Serial No.

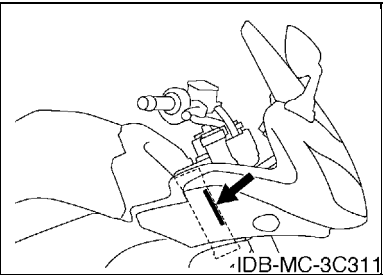
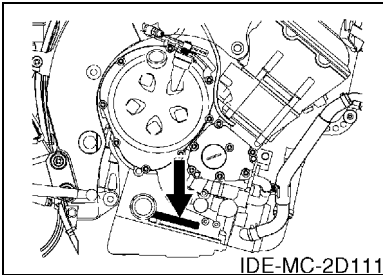

8. Applicable Colour Code (The (*) mark shows Model colour.)

Abbreviation	Colour Name	Colour Code
BNM5(*)	BLUISH GRAY METALLIC 5	1051
DPBMU(*)	DARK PURPLISH BLUE METALLIC U	0996
DRMK(*)	DEEP RED METALLIC K	0918
LGB	LOW GLOSS BLACK	0098
MBL2	MAT BLACK 2	0582
SMX	BLACK METALLIC X	0903

CONTENTS

ENGINE

CYLINDER HEAD	B2
CYLINDER	B4
CRANKSHAFT & PISTON	B5
VALVE	B6
CAMSHAFT & CHAIN	B8
WATER PUMP	B9
RADIATOR & HOSE	B11
OIL PUMP	B13
OIL CLEANER	B14
INTAKE	B15
INTAKE 2	C2
AIR INDUCTION SYSTEM	C4
EXHAUST	C5
CRANKCASE	C6
CRANKCASE COVER 1	C7
STARTER	C9
CLUTCH	C10
TRANSMISSION	C12
SHIFT CAM & FORK	C14
SHIFT SHAFT	C15

CHASSIS

FRAME	D2
FENDER	D4
SIDE COVER	D7
REAR ARM	D8
REAR SUSPENSION	D10
STEERING	D11
FRONT FORK	D12
FUEL TANK	D14
SEAT	E2
FRONT WHEEL	E3
FRONT BRAKE CALIPER	E4
REAR WHEEL	E5
REAR BRAKE CALIPER	E7
STEERING HANDLE & CABLE	E8
FRONT MASTER CYLINDER	E9
STAND & FOOTREST	E10
REAR MASTER CYLINDER	E13
COWLING 1	E14
GENERATOR	F2

STARTING MOTOR	F3
FLASHER LIGHT	F4
METER	F5
HEADLIGHT	F6
TAILLIGHT	F7
HANDLE SWITCH & LEVER	F8
ELECTRICAL 1	F9
ELECTRICAL 2	F11

INDEX

NUMERICAL INDEX	M1
-----------------------	----

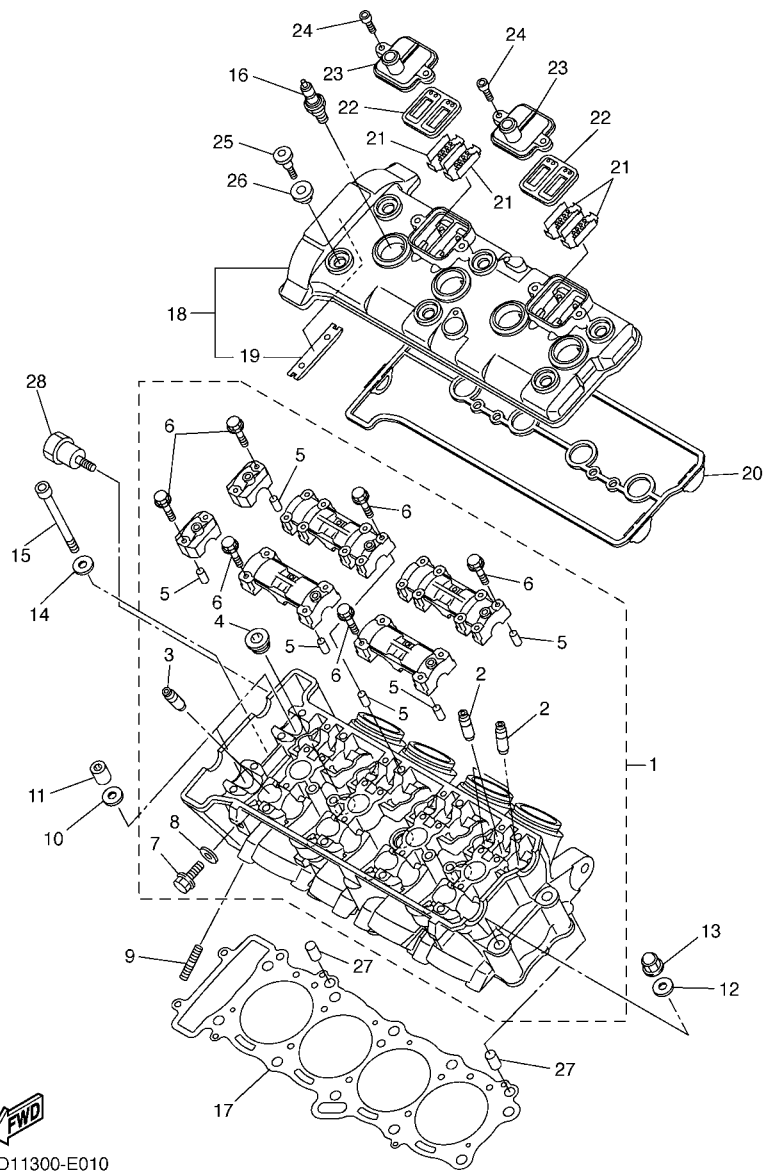

2D11300-E010

FIG. 1 CYLINDER HEAD

REF. NO.	PART NO.	DESCRIPTION	3C3A	3C3B	3C3C	REMARKS
1	5VY-11101-20	CYLINDER HEAD ASSY	1	1	1	
2	5VY-11133-10	.GUIDE, VALVE 1	12	12	12	
3	5VY-11134-10	.GUIDE, VALVE 2	8	8	8	
4	90340-18002	.PLUG, STRAIGHT SCREW	3	3	3	
5	91808-16023	.PIN, DOWEL	6	6	6	
6	90105-06026	.BOLT, FLANGE	28	28	28	
7	95024-06012	.BOLT, FLANGE	1	1	1	
8	90430-06014	.GASKET	1	1	1	
9	95612-08625	BOLT, STUD	8	8	8	
10	90201-10033	WASHER, PLATE	8	8	8	
11	90179-10006	NUT	8	8	8	
12	90201-10033	WASHER, PLATE	2	2	2	
13	90176-10075	NUT, CROWN	2	2	2	
14	90201-06034	WASHER, PLATE	2	2	2	
15	91314-06105	BOLT	2	2	2	
16	94701-00403	PLUG, SPARK (NGK CR9EK)	4	4	4	
17	2D1-11181-00	GASKET, CYLINDER HEAD 1	1	1	1	
18	5VY-11191-02	COVER, CYLINDER HEAD 1	1	1	1	
19	5BE-12241-00	.GUIDE, STOPPER 2	1	1	1	
20	5VY-11193-10	GASKET, HEAD COVER 1	1	1	1	
21	5VY-1482K-00	PLATE	4	4	4	
22	5SL-14890-10	REED VALVE ASSY	2	2	2	
23	5VY-14899-00	CAP, CASE	2	2	2	
24	90110-06178	BOLT, HEXAGON SOCKET HEAD	4	4	4	
25	90109-066F0	BOLT	6	6	6	
26	5VY-1111G-00	RUBBER, MOUNT 1	6	6	6	
27	99530-10114	PIN, DOWEL	2	2	2	

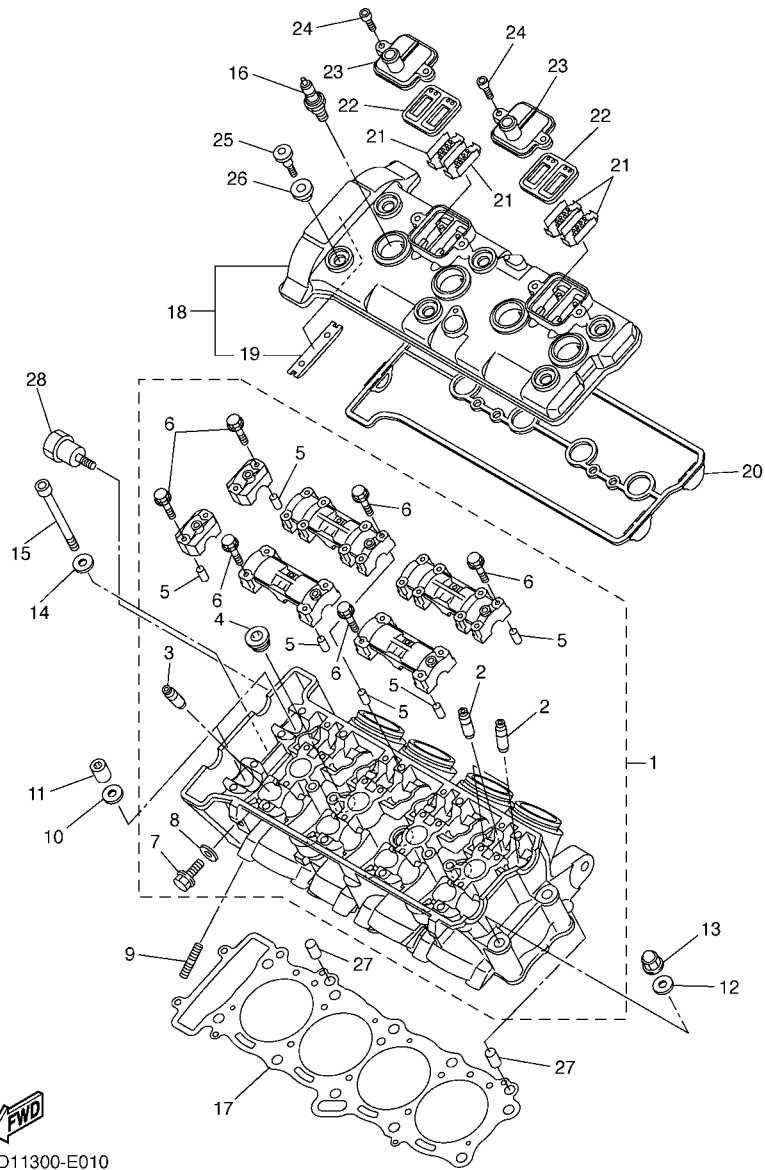

2D11300-E010

FIG. 1 CYLINDER HEAD

REF. NO.	PART NO.	DESCRIPTION	3C3A	3C3B	3C3C	REMARKS
28	2D1-11026-00	BOLT, MOUNT	1	1	1	

FIG. 2 CYLINDER

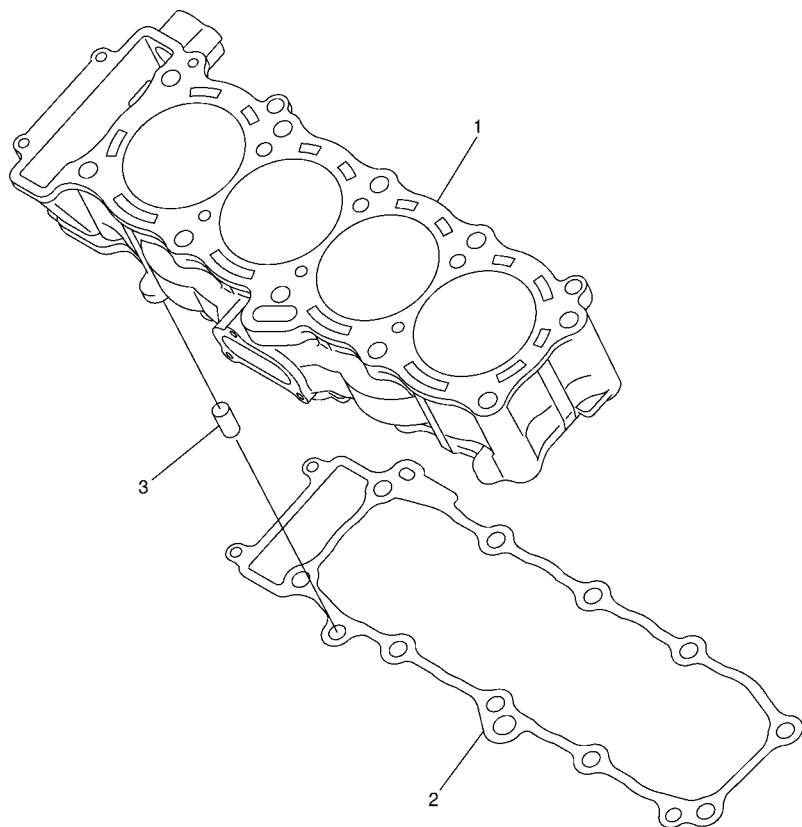

REF. NO.	PART NO.	DESCRIPTION	3C3A	3C3B	3C3C	REMARKS
1	5VY-11311-10	CYLINDER 1	1	1	1	
2	5VY-11351-00	GASKET, CYLINDER	1	1	1	
3	99530-10114	PIN, DOWEL	2	2	2	



5VY1300-C020

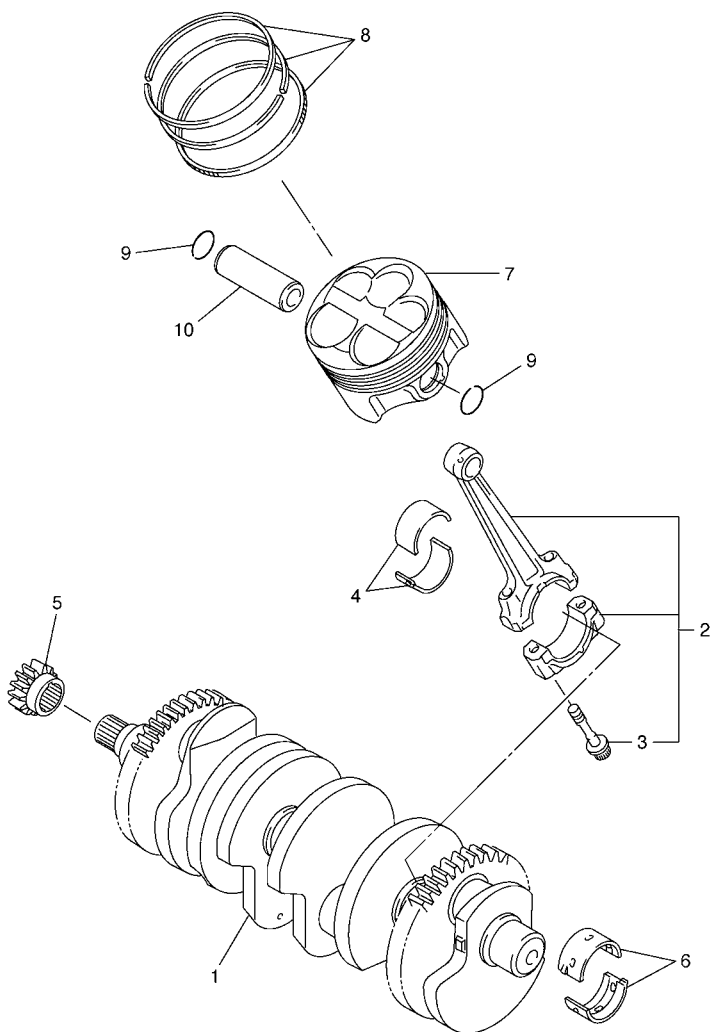
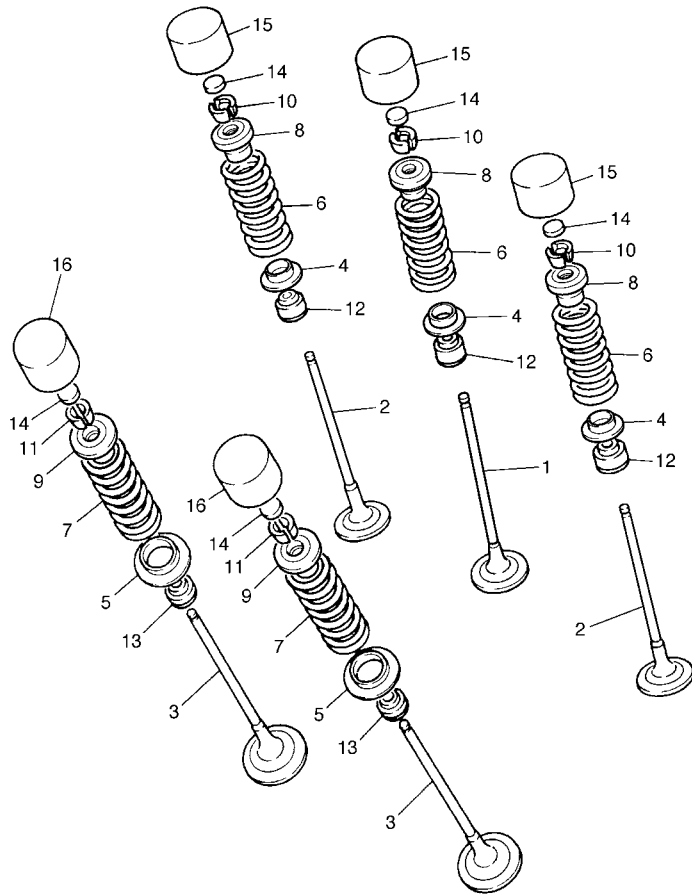

FIG. 3 CRANKSHAFT & PISTON

REF. NO.	PART NO.	DESCRIPTION	3C3A	3C3B	3C3C	REMARKS
1	2D1-11411-00	CRANKSHAFT	1	1	1	
2	4C8-11650-00	CONNECTING ROD ASSY	4	4	4	
3	5VY-11654-01	.BOLT, CONNECTING ROD	2	2	2	
4	2D1-11656-00	PLANE BEARING, CONNECTING ROD	8	8	8	UR BLUE
	2D1-11656-10	PLANE BEARING, CONNECTING ROD	8	8	8	UR BLACK
	2D1-11656-20	PLANE BEARING, CONNECTING ROD	8	8	8	UR BROWN
	2D1-11656-30	PLANE BEARING, CONNECTING ROD	8	8	8	UR GREEN
5	5VY-11549-00	SPROCKET, CAM CHAIN	1	1	1	
6	5VY-11416-A0	PLANE BEARING, CRANKSHAFT 1	10	10	10	UR WHITE
	5VY-11416-00	PLANE BEARING, CRANKSHAFT 1	10	10	10	UR BLUE
	5VY-11416-10	PLANE BEARING, CRANKSHAFT 1	10	10	10	UR BLACK
	5VY-11416-20	PLANE BEARING, CRANKSHAFT 1	10	10	10	UR BROWN
	5VY-11416-30	PLANE BEARING, CRANKSHAFT 1	10	10	10	UR GREEN
7	5VY-11631-10	PISTON (STD)	4	4	4	
8	5VY-11603-01	PISTON RING SET (STD)	4	4	4	
9	93450-18157	CIRCLIP	8	8	8	
10	5VY-11633-00	PIN, PISTON	4	4	4	

 2D11300-E030

FIG. 4 VALVE



REF. NO.	PART NO.	DESCRIPTION	3C3A	3C3B	3C3C	REMARKS
1	5VY-12111-00	VALVE, INTAKE	4	4	4	
2	5VY-12112-00	VALVE, INTAKE 2	8	8	8	
3	5VY-12121-00	VALVE, EXHAUST	8	8	8	
4	5NL-12116-00	SEAT, VALVE SPRING	12	12	12	
5	3GM-12126-00	SEAT, VALVE SPRING 2	8	8	8	
6	2D1-12113-00	SPRING, VALVE INNER	12	12	12	
7	2D1-12114-00	SPRING, VALVE OUTER	8	8	8	
8	1HX-12117-00	RETAINER, VALVE SPRING	12	12	12	
9	1WG-12117-00	RETAINER, VALVE SPRING	8	8	8	
10	1HX-12118-00	COTTER, VALVE	24	24	24	
11	1WG-12118-00	COTTER, VALVE	16	16	16	
12	4TV-12119-00	SEAL, VALVE STEM	12	12	12	
13	4SV-12119-00	SEAL, VALVE STEM	8	8	8	
14	1HX-12168-00	PAD, ADJUSTING 2 (1.20)	20	20	20	UR
	1HX-12168-20	PAD, ADJUSTING 2 (1.25)	20	20	20	UR
	1HX-12168-40	PAD, ADJUSTING 2 (1.30)	20	20	20	UR
	1HX-12168-60	PAD, ADJUSTING 2 (1.35)	20	20	20	UR
	1HX-12168-80	PAD, ADJUSTING 2 (1.40)	20	20	20	UR
	1HX-12168-A0	PAD, ADJUSTING 2 (1.45)	20	20	20	UR
	1HX-12168-F0	PAD, ADJUSTING 2 (1.50)	20	20	20	UR
	1HX-12168-H1	PAD, ADJUSTING 2 (1.55)	20	20	20	UR
	1HX-12168-K1	PAD, ADJUSTING 2 (1.60)	20	20	20	UR
	1HX-12168-M1	PAD, ADJUSTING 2 (1.65)	20	20	20	UR
	1HX-12168-R1	PAD, ADJUSTING 2 (1.70)	20	20	20	UR
	1HX-12168-U1	PAD, ADJUSTING 2 (1.75)	20	20	20	UR
	1HX-12168-W1	PAD, ADJUSTING 2 (1.80)	20	20	20	UR
	1HX-12168-Y1	PAD, ADJUSTING 2 (1.85)	20	20	20	UR



5VY1300-C040

B6

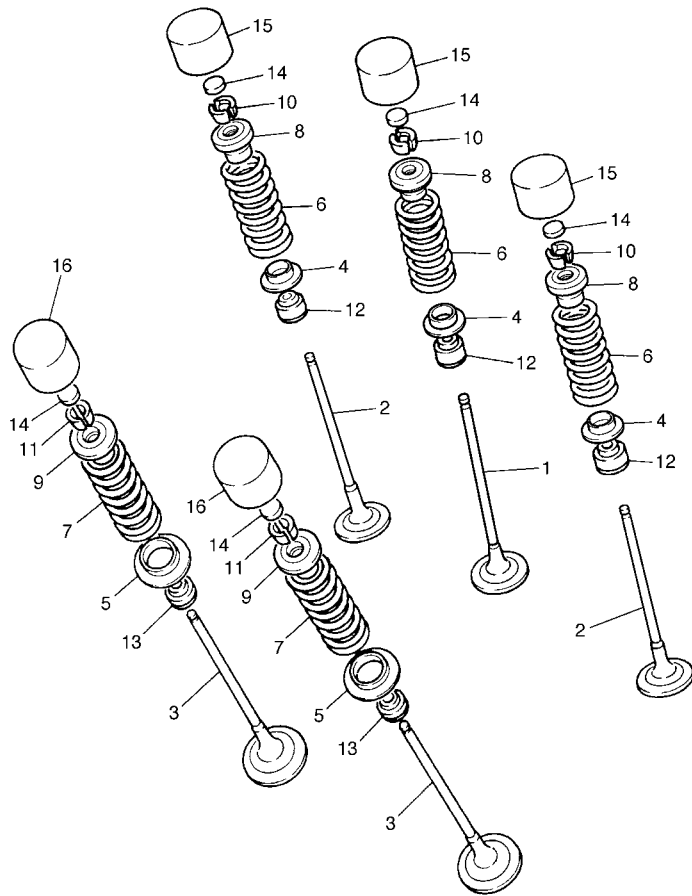

FIG. 4 VALVE

REF. NO.	PART NO.	DESCRIPTION	3C3A	3C3B	3C3C	REMARKS
14	1HX-12169-11	PAD, ADJUSTING 2 (1.90)	20	20	20	UR
	1HX-12169-31	PAD, ADJUSTING 2 (1.95)	20	20	20	UR
	1HX-12169-50	PAD, ADJUSTING 2 (2.00)	20	20	20	UR
	1HX-12169-70	PAD, ADJUSTING 2 (2.05)	20	20	20	UR
	1HX-12169-90	PAD, ADJUSTING 2 (2.10)	20	20	20	UR
	1HX-12169-E0	PAD, ADJUSTING 2 (2.15)	20	20	20	UR
	1HX-12169-G0	PAD, ADJUSTING 2 (2.20)	20	20	20	UR
	1HX-12169-J0	PAD, ADJUSTING 2 (2.25)	20	20	20	UR
	1HX-12169-L0	PAD, ADJUSTING 2 (2.30)	20	20	20	UR
	1HX-12169-N0	PAD, ADJUSTING 2 (2.35)	20	20	20	UR
	1HX-12169-T0	PAD, ADJUSTING 2 (2.40)	20	20	20	UR
15	3LN-12153-20	LIFTER, VALVE	12	12	12	UR BLUE
	3LN-12153-30	LIFTER, VALVE	12	12	12	UR RED
	3LN-12153-09	LIFTER, VALVE (O/S)	12	12	12	UR GREEN
16	3FV-12153-20	LIFTER, VALVE	8	8	8	UR BLUE
	3FV-12153-30	LIFTER, VALVE	8	8	8	UR RED
	3FV-12153-09	LIFTER, VALVE (O/S)	8	8	8	UR GREEN



5VY1300-C040

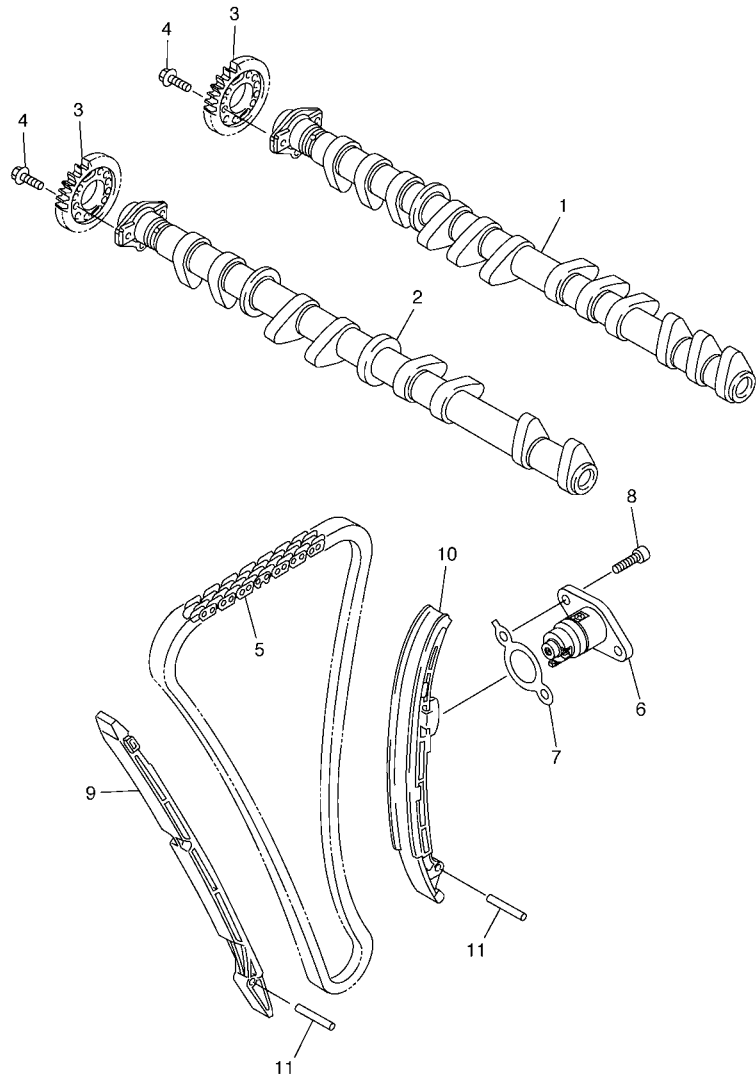
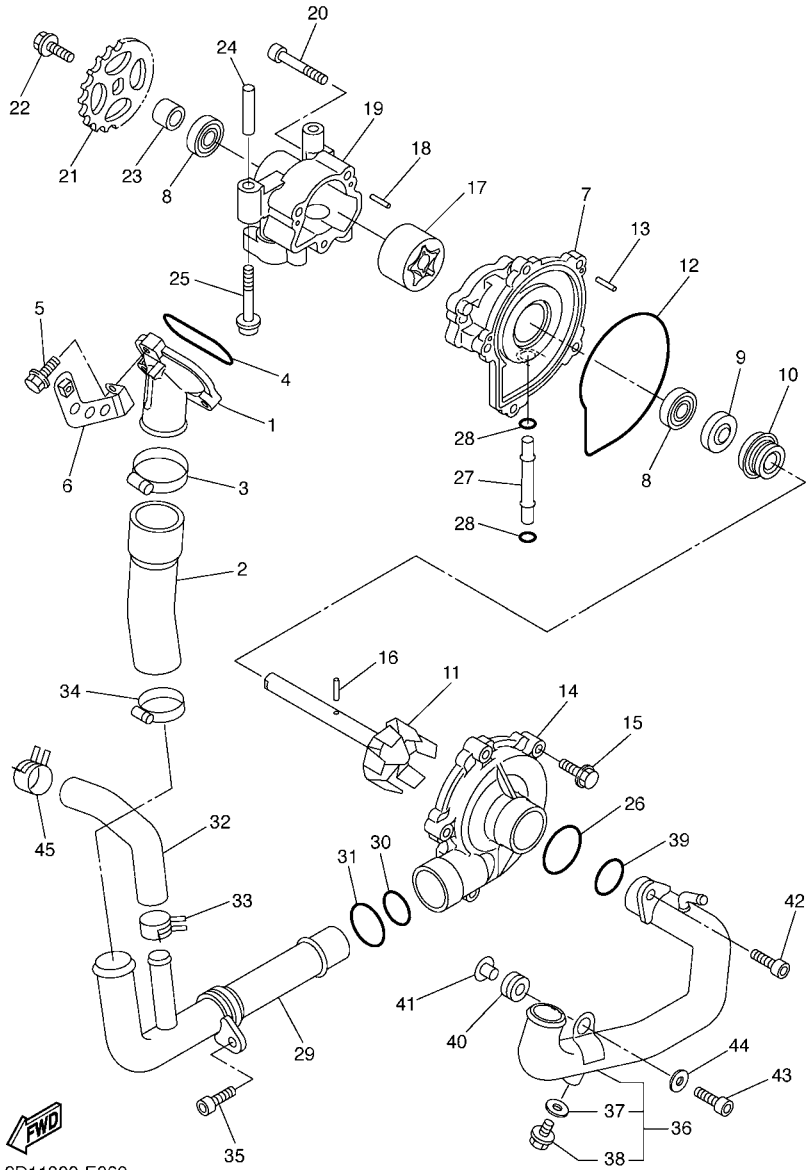

FIG. 5 CAMSHAFT & CHAIN

REF. NO.	PART NO.	DESCRIPTION	3C3A	3C3B	3C3C	REMARKS
1	2D1-12170-00	CAMSHAFT ASSY 1	1	1	1	
2	2D1-12180-00	CAMSHAFT ASSY 2	1	1	1	
3	5VY-12176-00	SPROCKET, CAM CHAIN	2	2	2	
4	90105-07006	BOLT, FLANGE	4	4	4	
5	94591-60122	CHAIN	1	1	1	
6	5VY-12210-20	TENSIONER ASSY, CAM CHAIN	1	1	1	
7	2D1-12213-00	GASKET, TENSIONER CASE	1	1	1	
8	91314-06020	BOLT	2	2	2	
9	5VY-12251-00	DAMPER, CHAIN 1	1	1	1	
10	5VY-12252-00	DAMPER, CHAIN 2	1	1	1	
11	93607-44002	PIN, DOWEL	2	2	2	



5VYE300-E050



2D11300-E060

FIG. 6 WATER PUMP

REF. NO.	PART NO.	DESCRIPTION	3C3A	3C3B	3C3C	REMARKS
1	5VY-12469-00	JOINT 1	1	1	1	
2	5VY-12576-00	HOSE 1	1	1	1	
3	90450-38040	HOSE CLAMP ASSY	1	1	1	
4	93210-47675	O-RING	1	1	1	
5	95024-06025	BOLT, FLANGE	3	3	3	
6	2D1-12637-00	STAY 1	1	1	1	
7	5VY-12421-01	HOUSING, WATER PUMP	1	1	1	
8	93306-00106	BEARING	2	2	2	
9	93102-12372	OIL SEAL	1	1	1	
10	11H-12438-10	SEAL, MECHANICAL	1	1	1	
11	5VY-12450-11	IMPELLER SHAFT ASSY	1	1	1	
12	4XV-12439-00	O-RING	1	1	1	
13	93603-12007	PIN, DOWEL	2	2	2	
14	5VY-12422-00	COVER, HOUSING	1	1	1	
15	90105-06065	BOLT, FLANGE	5	5	5	
16	93603-17070	PIN, DOWEL	1	1	1	
17	5VY-13310-10	ROTOR ASSY 1	1	1	1	
18	93603-12007	PIN, DOWEL	2	2	2	
19	5VY-13336-00	HOUSING, ROTOR	1	1	1	
20	91312-06040	BOLT	3	3	3	
21	5VY-13355-00	SPROCKET, DRIVEN	1	1	1	
22	90105-06066	BOLT, FLANGE	1	1	1	
23	5VY-12456-10	WASHER	1	1	1	
24	91808-30031	PIN, DOWEL	1	1	1	
25	90110-06167	BOLT, HEXAGON SOCKET HEAD	2	2	2	
26	93210-357A2	O-RING	1	1	1	
27	4XV-12485-00	PIPE 5	1	1	1	

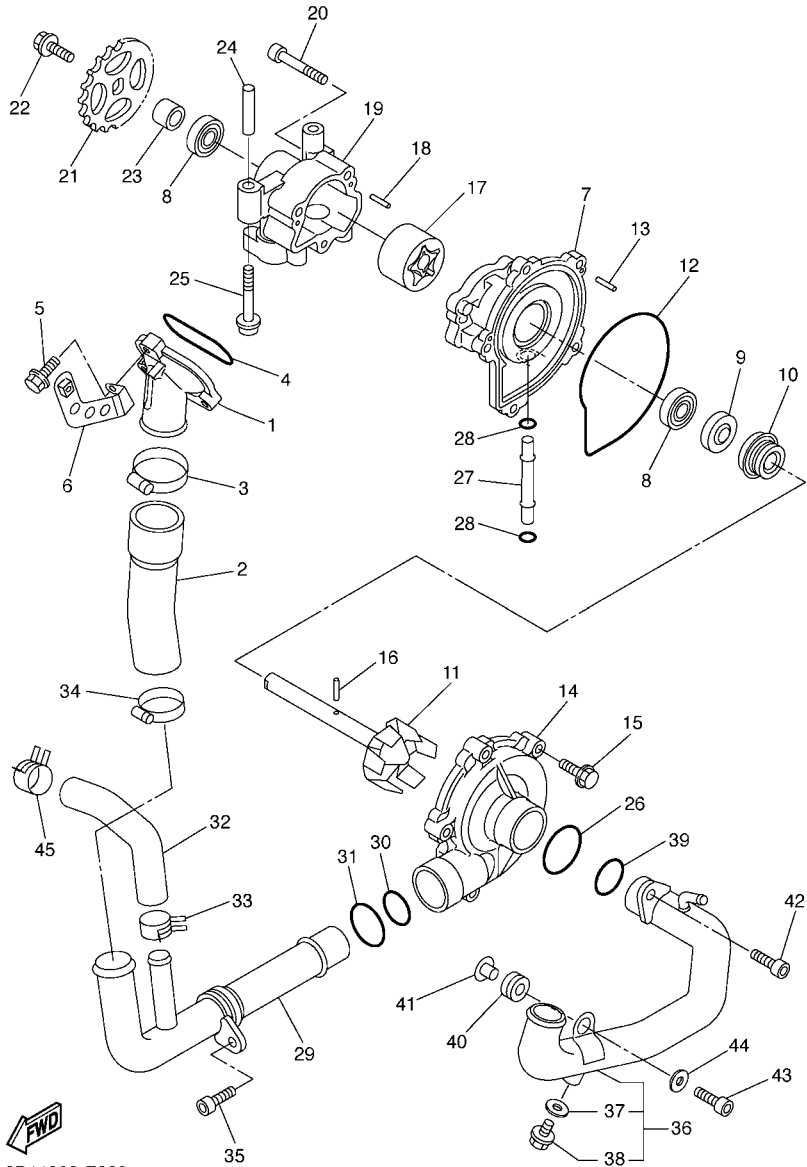

2D11300-E060

FIG. 6 WATER PUMP

REF. NO.	PART NO.	DESCRIPTION	3C3A	3C3B	3C3C	REMARKS
28	93210-06667	O-RING	2	2	2	
29	5VY-12481-10	PIPE 1	1	1	1	
30	93210-235A1	O-RING	1	1	1	
31	93210-27370	O-RING	1	1	1	
32	5VY-12588-00	HOSE 5	1	1	1	
33	90467-200A0	CLIP	1	1	1	
34	90450-32001	HOSE CLAMP ASSY	1	1	1	
35	90110-06161	BOLT, HEXAGON SOCKET HEAD	1	1	1	
36	2D1-12484-00	PIPE 4	1	1	1	
37	90430-06014	.GASKET	1	1	1	
38	90153-06002	.SCREW, HEXAGON	1	1	1	
39	93210-235A1	O-RING	1	1	1	
40	90480-12010	GROMMET	1	1	1	
41	90387-06112	COLLAR	1	1	1	
42	90110-06161	BOLT, HEXAGON SOCKET HEAD	1	1	1	
43	90110-06174	BOLT, HEXAGON SOCKET HEAD	1	1	1	
44	90201-06079	WASHER, PLATE	1	1	1	
45	90467-200A0	CLIP	1	1	1	

B10

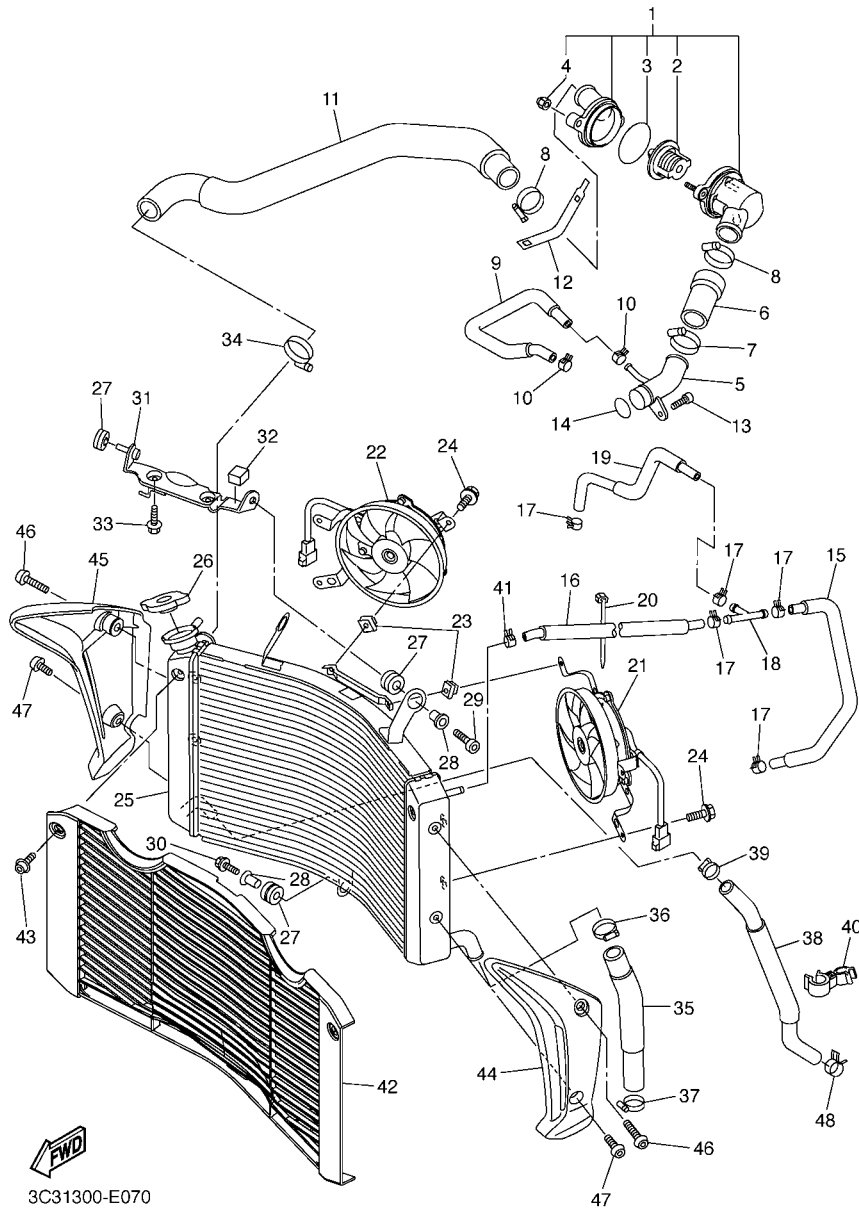

3C31300-E070

FIG. 7 RADIATOR & HOSE

REF. NO.	PART NO.	DESCRIPTION	3C3A	3C3B	3C3C	REMARKS
1	2D1-12410-00	THERMOSTAT ASSY	1	1	1	
2	5LP-12411-00	.THERMOSTAT	1	1	1	
3	93210-49046	.O-RING	1	1	1	
4	90176-06014	.NUT, CROWN	2	2	2	
5	5VY-12485-10	PIPE 5	1	1	1	
6	5VY-12579-00	HOSE 4	1	1	1	
7	90450-35001	HOSE CLAMP ASSY	1	1	1	
8	90450-38040	HOSE CLAMP ASSY	2	2	2	
9	5VY-1243F-00	HOSE,3	1	1	1	
10	90467-11090	CLIP	2	2	2	
11	2D1-12578-00	HOSE 3	1	1	1	
12	5GV-1246A-00	COVER 1	1	1	1	
13	90110-06168	BOLT, HEXAGON SOCKET HEAD	1	1	1	
14	93210-235A1	O-RING	1	1	1	
15	5VY-1243A-00	HOSE 1	1	1	1	
16	2D1-1244G-00	HOSE, 4	1	1	1	
17	90467-11090	CLIP	5	5	5	
18	90413-07023	WAY 3	1	1	1	
19	2D1-1243E-00	HOSE 2	1	1	1	
20	90464-13073	CLAMP	1	1	1	
21	2D1-12405-00	BLOWER ASSY	1	1	1	
22	2D1-12405-10	BLOWER ASSY	1	1	1	
23	1AA-12535-00	PLATE	2	2	2	
24	2D1-12675-00	BOLT, BLOWER HOLDING	6	6	6	
25	2D1-12461-00	RADIATOR ASSY	1	1	1	
26	22W-12462-00	CAP, RADIATOR	1	1	1	
27	90480-15363	GROMMET	3	3	3	

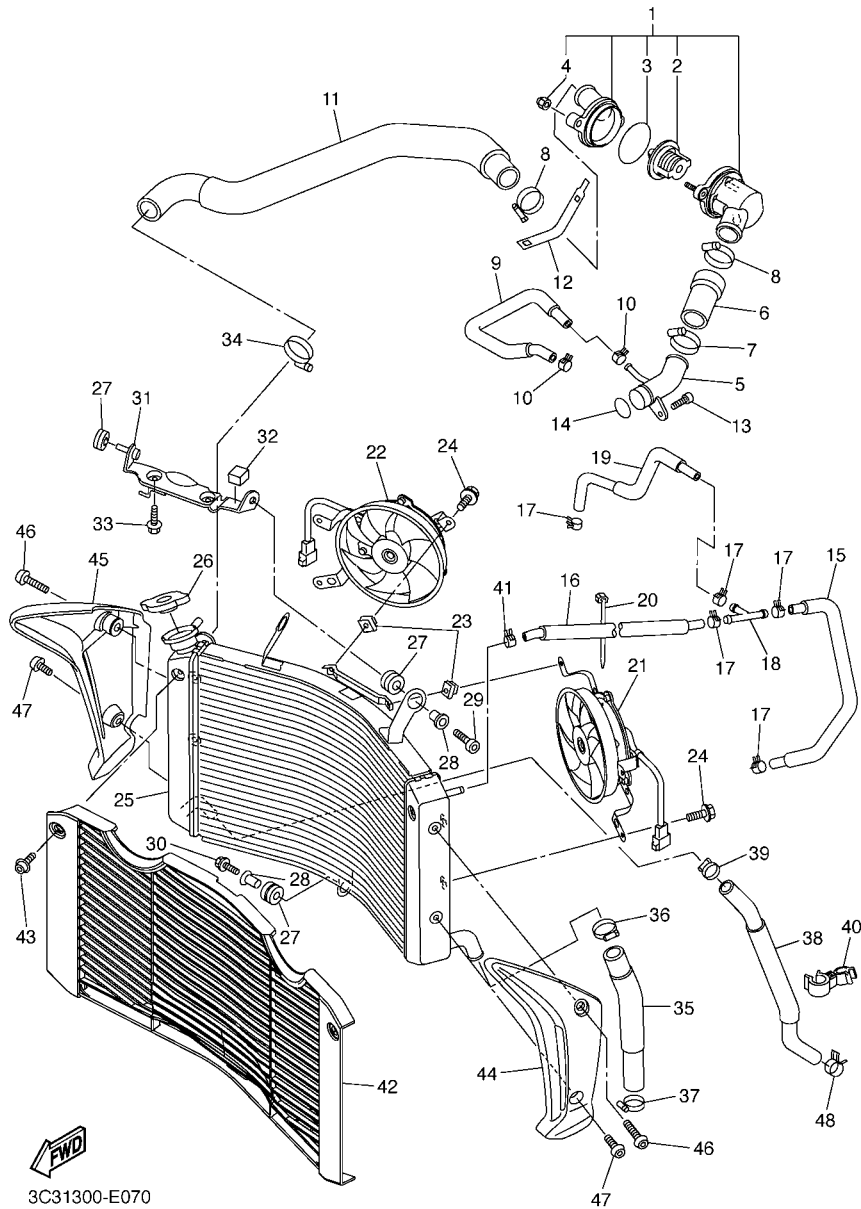

3C31300-E070

FIG. 7 RADIATOR & HOSE

REF. NO.	PART NO.	DESCRIPTION	3C3A	3C3B	3C3C	REMARKS
28	90387-07391	COLLAR	2	2	2	
29	90109-06015	BOLT	1	1	1	
30	90109-067E6	BOLT	1	1	1	
31	2D1-12464-00	STAY, RADIATOR	1	1	1	
32	2D1-2139U-00	DAMPER 2	1	1	1	
33	95807-06012	BOLT, FLANGE	2	2	2	
34	90450-35001	HOSE CLAMP ASSY	1	1	1	
35	2D1-12551-00	HOSE 7	1	1	1	
36	90450-35001	HOSE CLAMP ASSY	1	1	1	
37	90450-32001	HOSE CLAMP ASSY	1	1	1	
38	2D1-12589-00	HOSE 6	1	1	1	
39	90450-22017	HOSE CLAMP ASSY	1	1	1	
40	90464-23002	CLAMP	1	1	1	
41	90467-11090	CLIP	1	1	1	
42	2D1-12467-00	COVER, RADIATOR	1	1	1	
43	90111-06031	BOLT, HEX. SOCKET BUTTON	2	2	2	
44	3C3-1240J-00-P0	RADIATOR COVER ASSY1	1	1	1	MBL2
45	3C3-1240K-00-P0	RADIATOR COVER ASSY 2	1	1	1	MBL2
46	90111-06080	BOLT, HEX. SOCKET BUTTON	2	2	2	
47	90111-06079	BOLT, HEX. SOCKET BUTTON	2	2	2	
48	90467-200A0	CLIP	1	1	1	

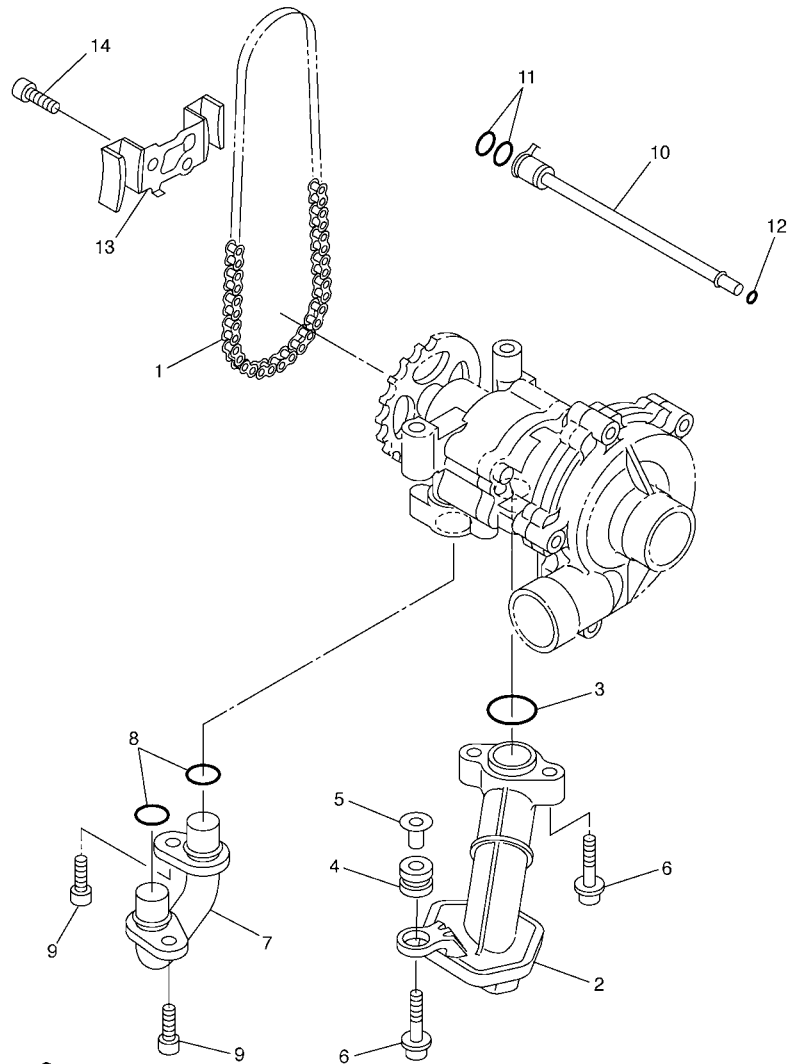

5VY1300-C080

FIG. 8 OIL PUMP

REF. NO.	PART NO.	DESCRIPTION	3C3A	3C3B	3C3C	REMARKS
1	94580-25078	CHAIN (DID25 78LE)	1	1	1	
2	5VY-13410-00	STRAINER HOUSING ASSY	1	1	1	
3	93210-22298	O-RING	1	1	1	
4	90480-13010	GROMMET	1	1	1	
5	5VY-13117-10	COLLAR, DISTANCE	1	1	1	
6	90110-06173	BOLT, HEXAGON SOCKET HEAD	3	3	3	
7	5VY-13416-00	PIPE, OIL 1	1	1	1	
8	93210-14003	O-RING	2	2	2	
9	90110-06161	BOLT, HEXAGON SOCKET HEAD	2	2	2	
10	5VY-1316E-00	PIPE, DELIVERY 5	1	1	1	
11	93210-09165	O-RING	2	2	2	
12	93210-06667	O-RING	1	1	1	
13	5VY-13898-00	HOLDER	1	1	1	
14	90110-06182	BOLT, HEXAGON SOCKET HEAD	2	2	2	

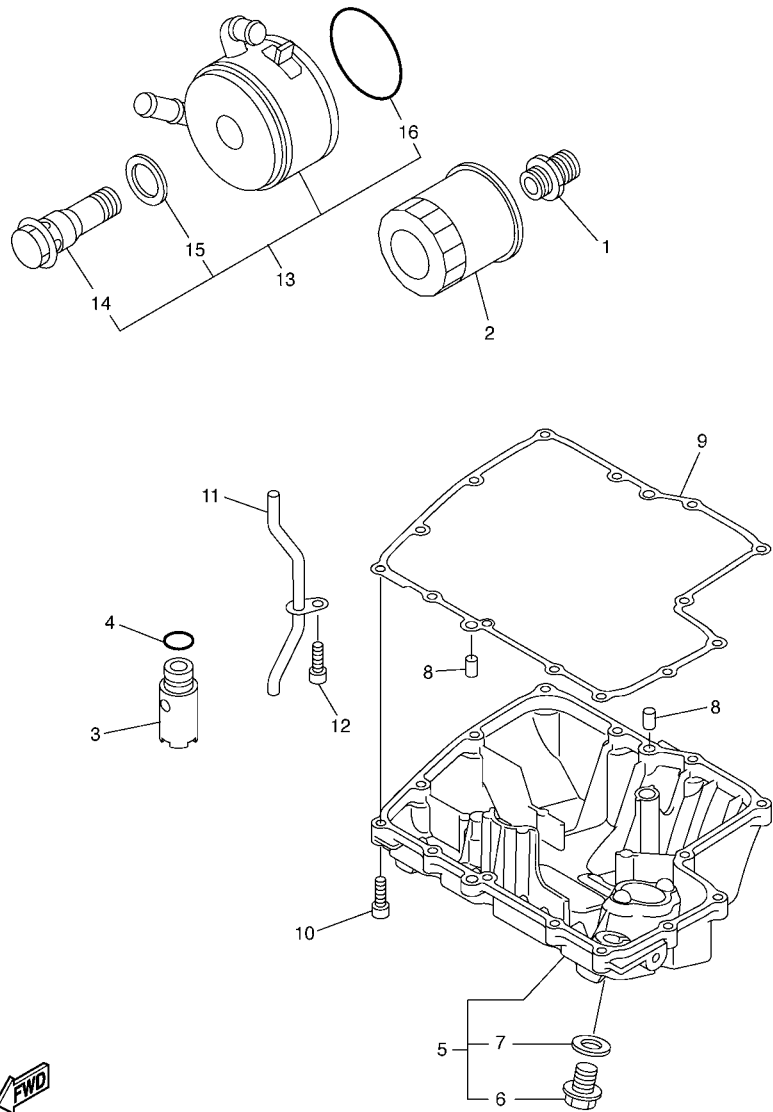
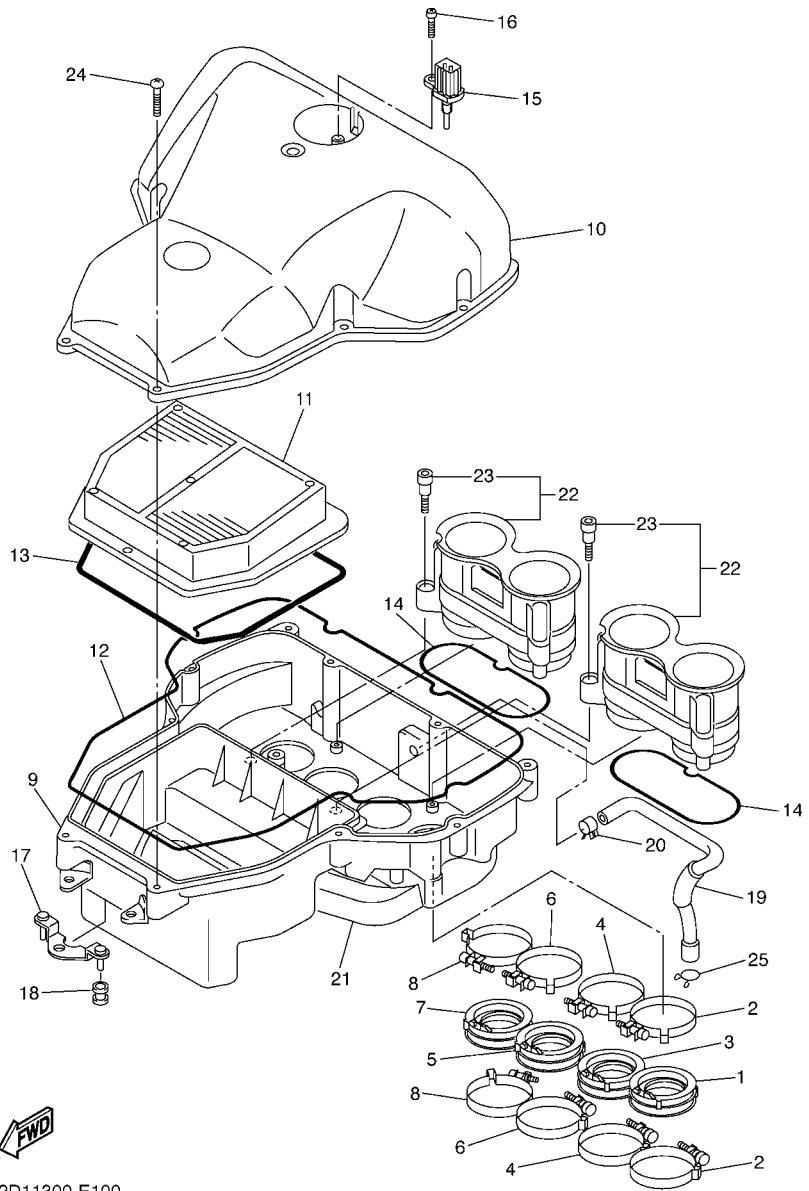

FIG. 9 OIL CLEANER

REF. NO.	PART NO.	DESCRIPTION	3C3A	3C3B	3C3C	REMARKS
1	90401-20145	BOLT, UNION	1	1	1	
2	5GH-13440-20	ELEMENT ASSY, OIL CLEANER	1	1	1	
3	5VY-13490-00	RELIEF VALVE ASSY	1	1	1	
4	93210-15566	O-RING	1	1	1	
5	2D1-13417-10	COVER, STRAINER	1	1	1	
6	90340-14132	.PLUG, STRAIGHT SCREW	1	1	1	
7	214-11198-01	.GASKET	1	1	1	
8	99530-08012	PIN, DOWEL	2	2	2	
9	4C8-13414-00	GASKET, STRAINER COVER	1	1	1	
10	91312-06025	BOLT	14	14	14	
11	5VY-13161-00	PIPE, DELIVERY 1	1	1	1	
12	90110-06182	BOLT, HEXAGON SOCKET HEAD	1	1	1	
13	5VY-13470-00	OIL COOLER ASSY	1	1	1	
14	5EB-12822-00	.BOLT, UNION	1	1	1	
15	5EB-13475-00	.GASKET	1	1	1	
16	5JW-13473-00	.O-RING	1	1	1	



2D14300-F090



2D11300-E100

FIG. 10 INTAKE

REF. NO.	PART NO.	DESCRIPTION	3C3A	3C3B	3C3C	REMARKS
1	5VY-13595-00	JOINT	1	1	1	
2	90450-62002	HOSE CLAMP ASSY	2	2	2	
3	5VY-13596-00	JOINT, CARBURETOR 2	1	1	1	
4	90450-62002	HOSE CLAMP ASSY	2	2	2	
5	5VY-13597-00	JOINT, CARBURETOR 3	1	1	1	
6	90450-62002	HOSE CLAMP ASSY	2	2	2	
7	5VY-13598-00	JOINT, CARBURETOR 4	1	1	1	
8	90450-62002	HOSE CLAMP ASSY	2	2	2	
9	2D1-14411-00	CASE, AIR CLEANER 1	1	1	1	
10	2D1-14421-00	CASE, AIR CLEANER 2	1	1	1	
11	2D1-14451-00	ELEMENT, AIR CLEANER	1	1	1	
12	2D1-14452-00	SEAL	1	1	1	
13	2D1-14462-00	SEAL	1	1	1	
14	5VY-14457-00	SEAL	2	2	2	
15	8FP-85886-00	SENSOR, AIR TEMPERATURE	1	1	1	
16	97702-50520	SCREW, TAPPING	1	1	1	
17	2D1-14498-00	STAY 1	1	1	1	
18	90480-08264	GROMMET	2	2	2	
19	2D1-15393-00	PIPE, BREATHER 2	1	1	1	
20	90467-14171	CLIP	1	1	1	
21	2D1-14409-00	DAMPEN	1	1	1	
22	2D1-1440B-00	JOINT ASSY	2	2	2	
23	90109-05005	.BOLT	3	3	3	
24	97702-50025	SCREW, TAPPING	11	11	11	
25	90467-14015	CLIP	1	1	1	

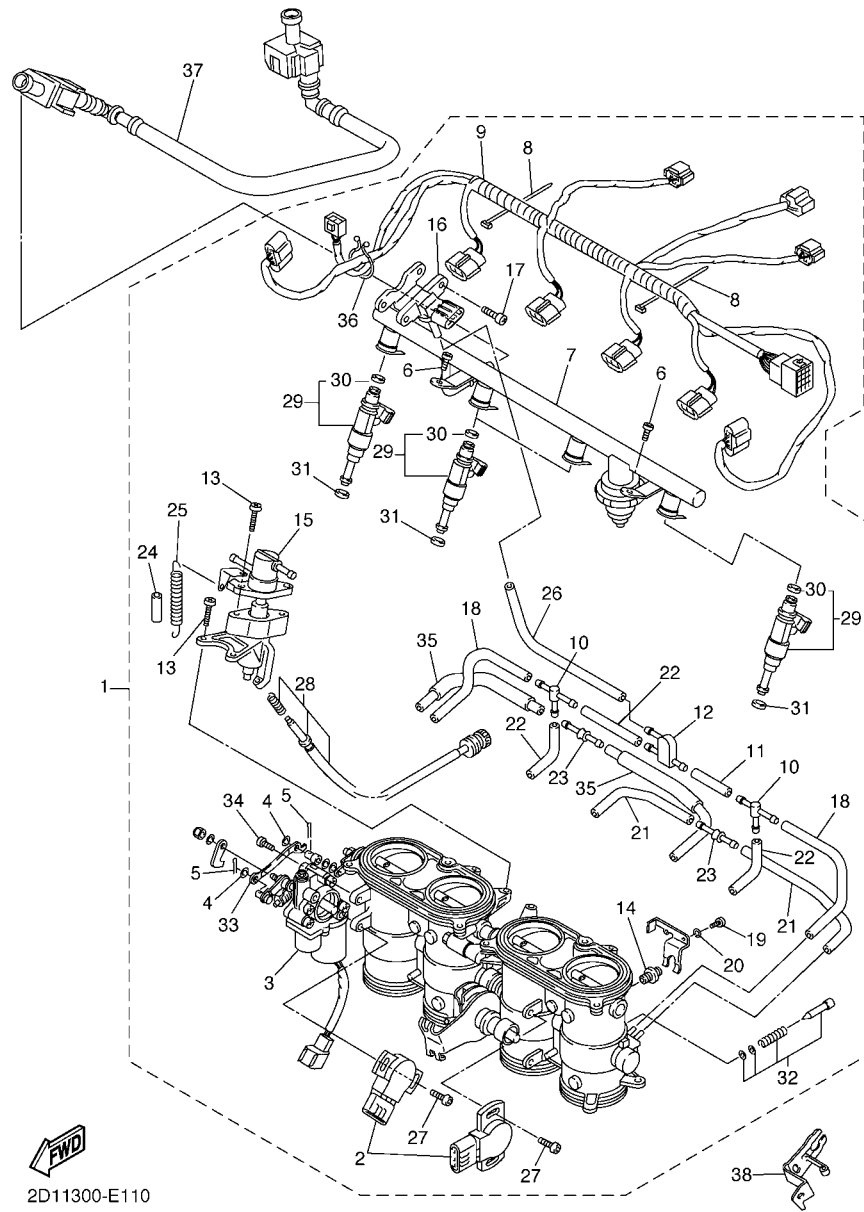

2D11300-E110

FIG. 11 INTAKE 2

REF. NO.	PART NO.	DESCRIPTION	3C3A	3C3B	3C3C	REMARKS
1	2D1-13750-00	THROTTLE BODY ASSY	1	1	1	
2	5FL-85885-02	.THROTTLE SENSOR ASSY	2	2	2	
3	5VY-85850-00	.GEARED MOTOR COMP.	1	1	1	
4	22U-14952-00	.WASHER	2	2	2	
5	91492-12010	.PIN, COTTER	2	2	2	
6	98502-06012	.SCREW, PAN HEAD	2	2	2	
7	2D1-13160-00	.DELIVERY PIPE ASSY 1	1	1	1	
8	4KM-14137-00	.CLIP	5	5	5	
9	2D1-82386-00	.EXTENSION, WIRE HARNESS	1	1	1	
10	68V-24376-00	.PIPE, JOINT 1	2	2	2	
11	5JW-14396-00	.PIPE	1	1	1	
12	3XV-14251-00	.NIPPLE	1	1	1	
13	98502-05014	.SCREW, PAN HEAD	4	4	4	
14	5VY-14171-00	.PLUNGER, STARTER	2	2	2	
15	5VY-14204-00	.CASE, STARTER	1	1	1	
16	1C7-82380-00	.SENSOR, PRESSURE	1	1	1	
17	92502-06010	.SCREW, PAN HEAD	2	2	2	
18	5FL-14349-10	.PIPE	2	2	2	
19	98507-03016	.SCREW, PAN HEAD	4	4	4	
20	92990-03100	.WASHER, SPRING	4	4	4	
21	5PW-14349-00	.PIPE	2	2	2	
22	5PS-14987-00	.HOSE	3	3	3	
23	5PW-14251-00	.NIPPLE	2	2	2	
24	5DM-14936-00	.SEAT, SPRING	1	1	1	
25	5JW-14589-00	.SPRING	1	1	1	
26	5SL-14349-00	.PIPE	1	1	1	
27	8CC-14216-10	.SCREW	4	4	4	

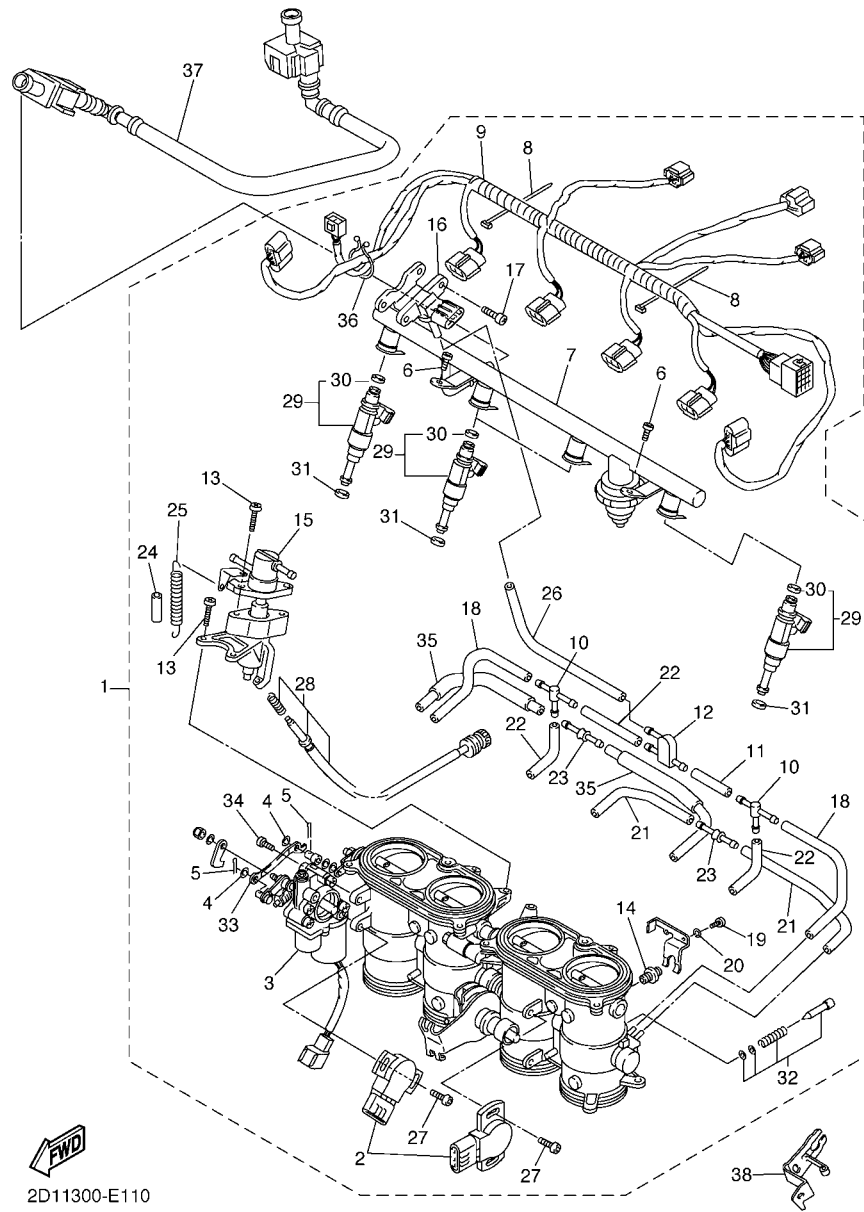

2D11300-E110

FIG. 11 INTAKE 2

REF. NO.	PART NO.	DESCRIPTION	3C3A	3C3B	3C3C	REMARKS
28	5PW-14103-00	.THROTTLE SCREW SET	1	1	1	
29	5VY-13761-00	.INJECTOR ASSY	4	4	4	
30	5PS-14147-00	.O-RING	1	1	1	
31	8FP-13556-00	.GASKET, MANIFOLD	4	4	4	
32	5JW-14104-00	.AIR SCREW SET	2	2	2	
33	5VY-14905-00	.LEVER, STARTER	1	1	1	
34	98507-06020	.SCREW, PAN HEAD	2	2	2	
35	5VY-13543-00	.HOSE, AIR	2	2	2	
36	90464-30040	.CLAMP	1	1	1	
37	2D1-13971-00	PIPE, FUEL 1	1	1	1	
38	2D1-14413-00	STAY	1	1	1	

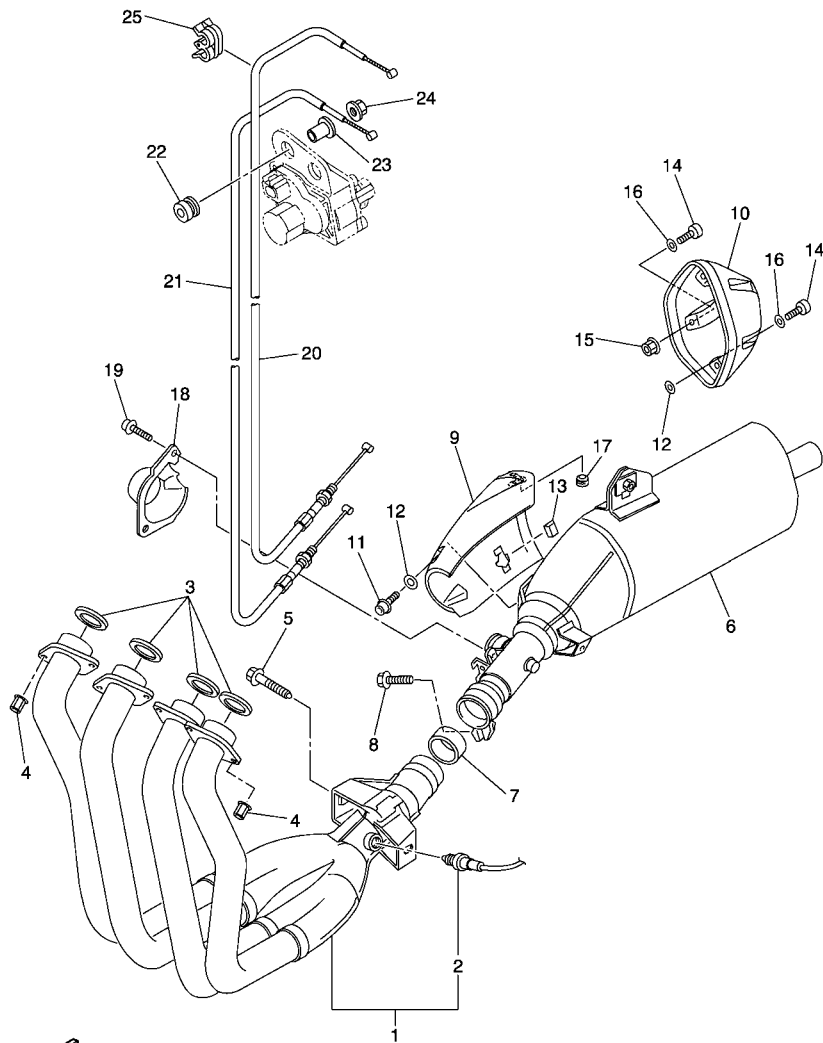

2D14300-F130

FIG. 13 EXHAUST

REF. NO.	PART NO.	DESCRIPTION	3C3A	3C3B	3C3C	REMARKS
1	2D1-14602-00	EXHAUST PIPE COMP.	1	1	1	
2	2D1-8592A-00	.SENSOR	1	1	1	
3	4FM-14613-00	GASKET, EXHAUST PIPE	4	4	4	
4	90179-08410	NUT	8	8	8	
5	90109-08170	BOLT	2	2	2	
6	2D1-14703-00	MUFFLER COMP. 1	1	1	1	
7	5VY-14755-00	GASKET, SILENCER	1	1	1	
8	95814-08030	BOLT, FLANGE	1	1	1	
9	2D1-14718-10	PROTECTOR, MUFFLER 1	1	1	1	
10	2D1-14799-00	CAP	1	1	1	
11	90111-06060	BOLT,HEX. SOCKET BUTTON	2	2	2	
12	90201-05017	WASHER, PLATE	6	6	6	
13	3MA-24181-00	DAMPER, LOCATING 1	2	2	2	
14	91380-06014	BOLT	5	5	5	
15	95702-06500	NUT, FLANGE	1	1	1	
16	92990-06600	WASHER, PLATE	5	5	5	
17	2D1-14737-00	DAMPER, MUFFLER	1	1	1	
18	2D1-14826-00	PROTECTOR, EXHAUST	1	1	1	
19	90110-06110	BOLT, HEXAGON SOCKET HEAD	2	2	2	
20	2D1-1133E-00	CABLE, PULLEY 1	1	1	1	
21	2D1-1133F-10	CABLE, PULLEY 2	1	1	1	
22	90480-14604	GROMMET	2	2	2	
23	90387-06M60	COLLAR	1	1	1	
24	95702-06500	NUT, FLANGE	1	1	1	
25	90464-04001	CLAMP	1	1	1	

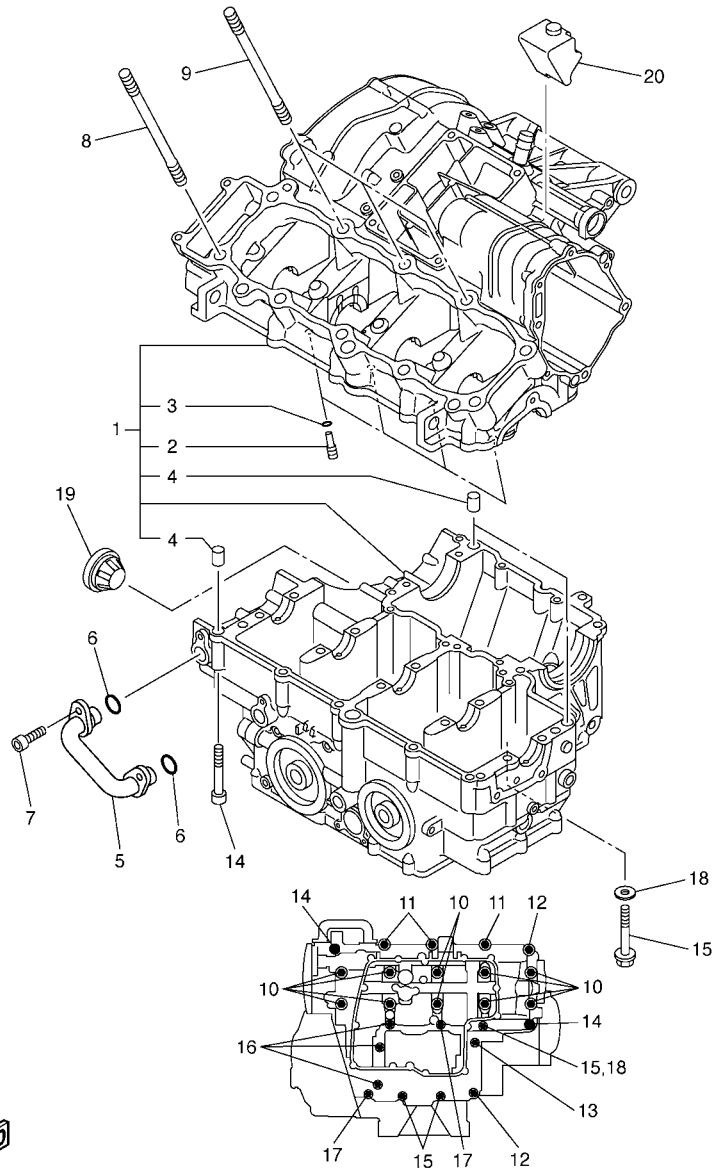
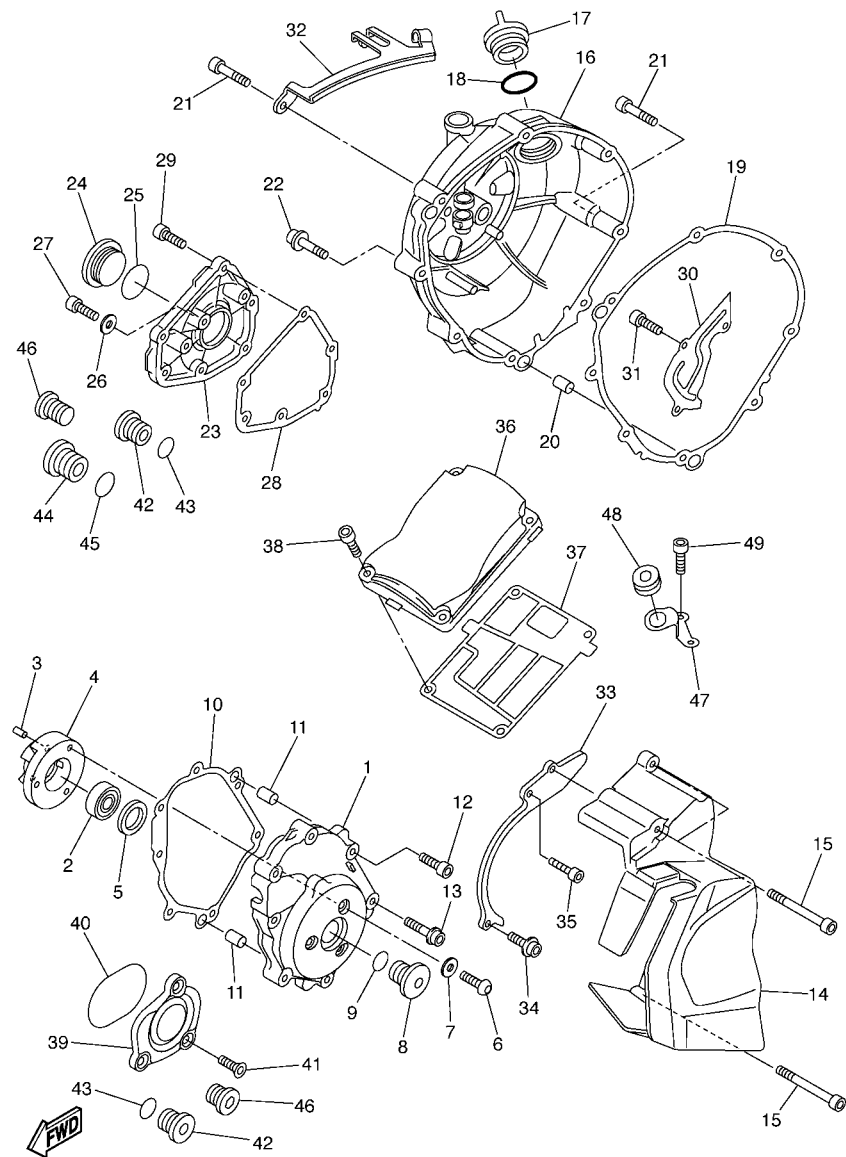

FIG. 14 CRANKCASE

REF. NO.	PART NO.	DESCRIPTION	3C3A	3C3B	3C3C	REMARKS
1	4C8-15100-00	CRANKCASE ASSY	1	1	1	
2	5EB-15155-00	.NOZZLE 3	4	4	4	
3	93210-04092	.O-RING	4	4	4	
4	99530-10014	.PIN, DOWEL	3	3	3	
5	5VY-13418-10	PIPE, OIL 2	1	1	1	
6	93210-14003	O-RING	2	2	2	
7	90110-06161	BOLT, HEXAGON SOCKET HEAD	2	2	2	
8	90116-10032	BOLT, STUD	7	7	7	
9	90116-10023	BOLT, STUD	3	3	3	
10	90119-09003	BOLT, WITH WASHER	10	10	10	
11	95812-08050	BOLT, FLANGE	3	3	3	
12	95812-08060	BOLT, FLANGE	2	2	2	
13	90105-08101	BOLT, FLANGE	1	1	1	
14	90109-06100	BOLT	2	2	2	
15	95812-06060	BOLT, FLANGE	3	3	3	
16	95812-06070	BOLT, FLANGE	3	3	3	
17	95812-06050	BOLT, FLANGE	2	2	2	
18	90430-06166	GASKET	1	1	1	
19	5PW-15361-00	GAUGE, LEVEL	1	1	1	
20	5VY-15316-00	DAMPER, ENGINE MOUNT 1	1	1	1	



5VY1300-C140



2D14300-F150

FIG. 15 CRANKCASE COVER 1

REF. NO.	PART NO.	DESCRIPTION	3C3A	3C3B	3C3C	REMARKS
1	5VY-15411-00	COVER, CRANKCASE 1	1	1	1	
2	93306-20124	BEARING	1	1	1	
3	93605-10108	PIN, DOWEL	2	2	2	
4	5VY-15164-00	HOUSING, BEARING 2	1	1	1	
5	5VY-15542-00	COLLAR 2	1	1	1	
6	90149-06064	SCREW	3	3	3	
7	90201-06431	WASHER, PLATE	3	3	3	
8	5PX-15189-00	PLUG	1	1	1	
9	93210-22382	O-RING	1	1	1	
10	2D1-15451-10	GASKET, CRANKCASE COVER 1	1	1	1	
11	99480-10018	PIN	2	2	2	
12	90109-06031	BOLT	4	4	4	
13	90110-08068	BOLT, HEXAGON SOCKET HEAD	3	3	3	
14	2D1-15418-00	COVER, CHAIN CASE	1	1	1	
15	90110-06255	BOLT, HEXAGON SOCKET HEAD	3	3	3	
16	2D1-15421-00	COVER, CRANKCASE 2	1	1	1	
17	3F9-15362-00	PLUG, OIL LEVEL	1	1	1	
18	93210-27194	O-RING	1	1	1	
19	4C8-15461-00	GASKET, CRANKCASE COVER 2	1	1	1	
20	93610-20189	PIN, DOWEL	2	2	2	
21	90109-06016	BOLT	7	7	7	
22	90110-06112	BOLT, HEXAGON SOCKET HEAD	1	1	1	
23	2D1-15416-00	COVER, OIL PUMP	1	1	1	
24	90340-32004	PLUG, STRAIGHT SCREW	1	1	1	
25	93210-32172	O-RING	1	1	1	
26	90430-08143	GASKET	1	1	1	
27	92014-08012	BOLT, BUTTON HEAD	1	1	1	

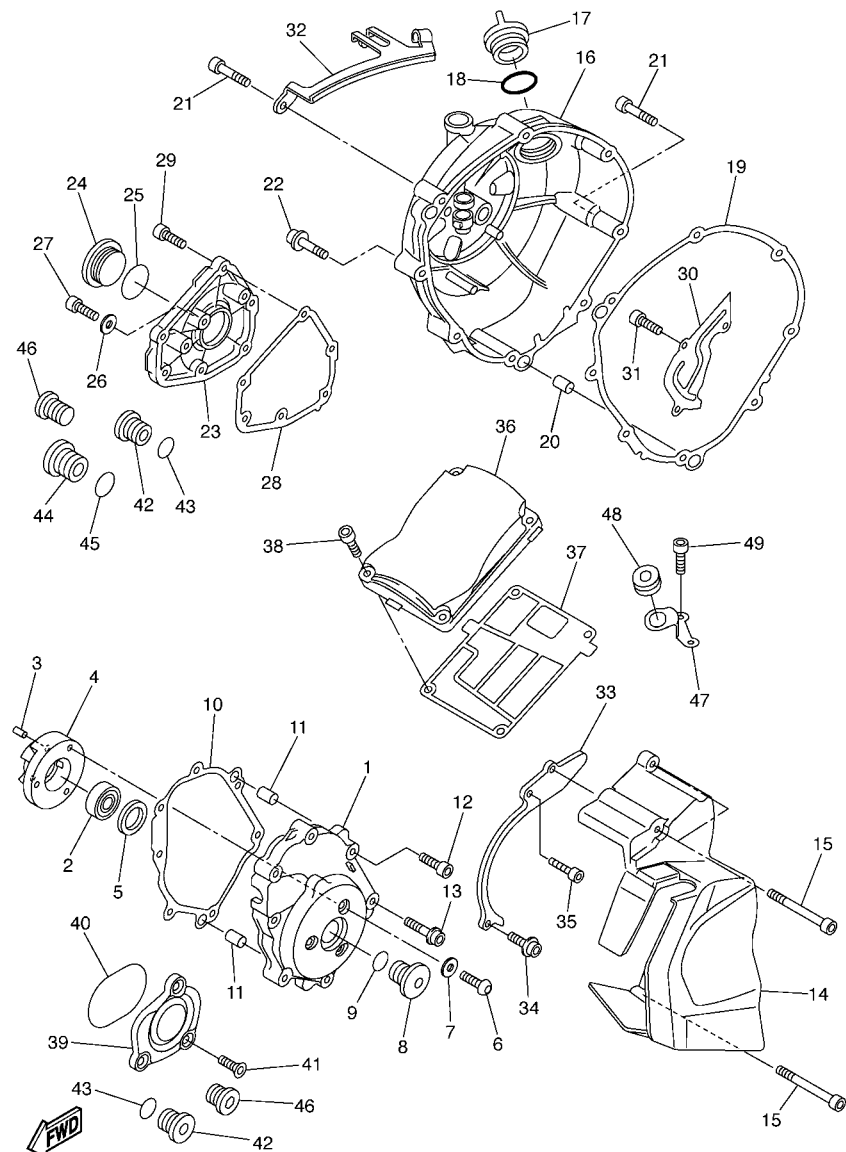

2D14300-F150

FIG. 15 CRANKCASE COVER 1

REF. NO.	PART NO.	DESCRIPTION	3C3A	3C3B	3C3C	REMARKS
28	4C8-15456-00	GASKET, OIL PUMP COVER 1	1	1	1	
29	90109-06014	BOLT	6	6	6	
30	5VY-11165-00	PLATE, BREATHER	1	1	1	
31	90110-06182	BOLT, HEXAGON SOCKET HEAD	3	3	3	
32	2D1-15441-00	HOLDER, CLUTCH CABLE	1	1	1	
33	4B1-15113-00	PLATE	1	1	1	
34	90110-06168	BOLT, HEXAGON SOCKET HEAD	1	1	1	
35	90110-06108	BOLT, HEXAGON SOCKET HEAD	1	1	1	
36	2D1-15413-00	COVER	1	1	1	
37	4C8-15462-00	GASKET, CRANKCASE COVER 3	1	1	1	
38	90109-06015	BOLT	4	4	4	
39	5VY-15431-00	COVER, CRANKCASE 3	1	1	1	
40	93210-57003	O-RING	1	1	1	
41	90151-06022	SCREW, COUNTERSUNK	3	3	3	
42	36Y-15189-00	PLUG	3	3	3	
43	93210-16325	O-RING	3	3	3	
44	4H7-15189-00	PLUG	1	1	1	
45	93210-22382	O-RING	1	1	1	
46	90340-12003	PLUG, STRAIGHT SCREW	2	2	2	
47	5VY-12443-10	STAY	1	1	1	
48	90480-13014	GROMMET	1	1	1	
49	91380-06014	BOLT	2	2	2	

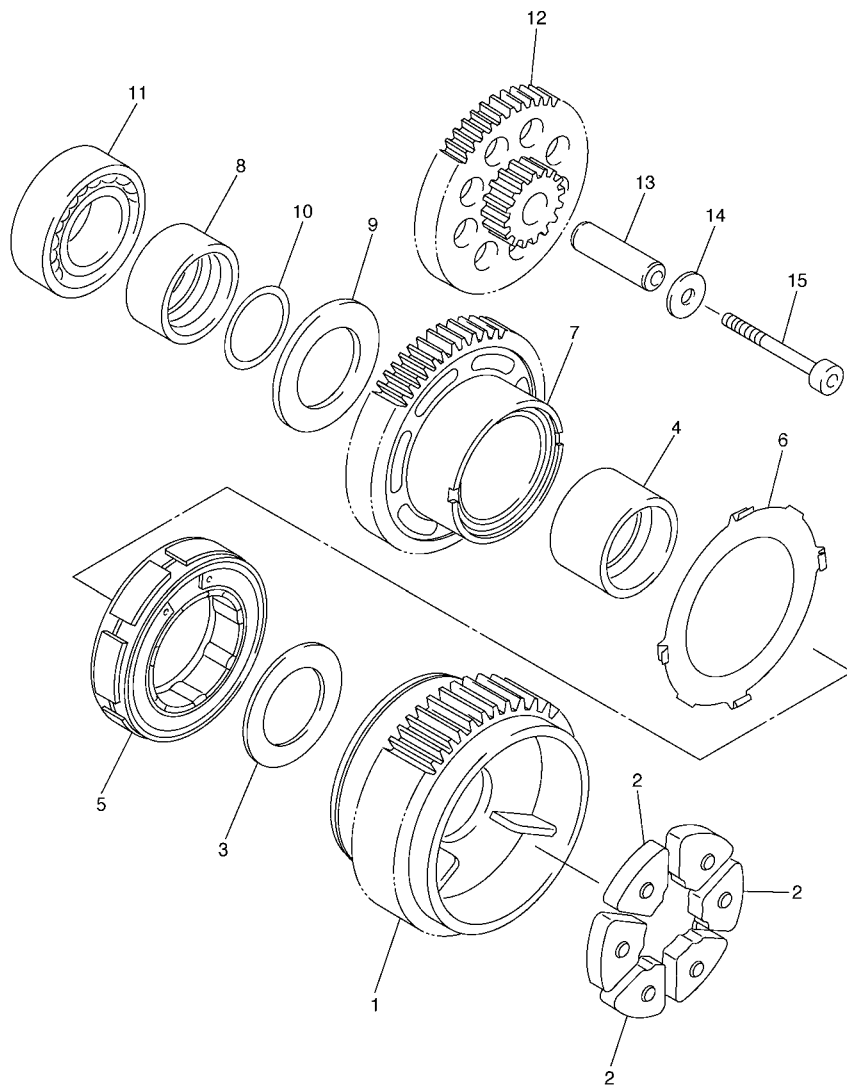
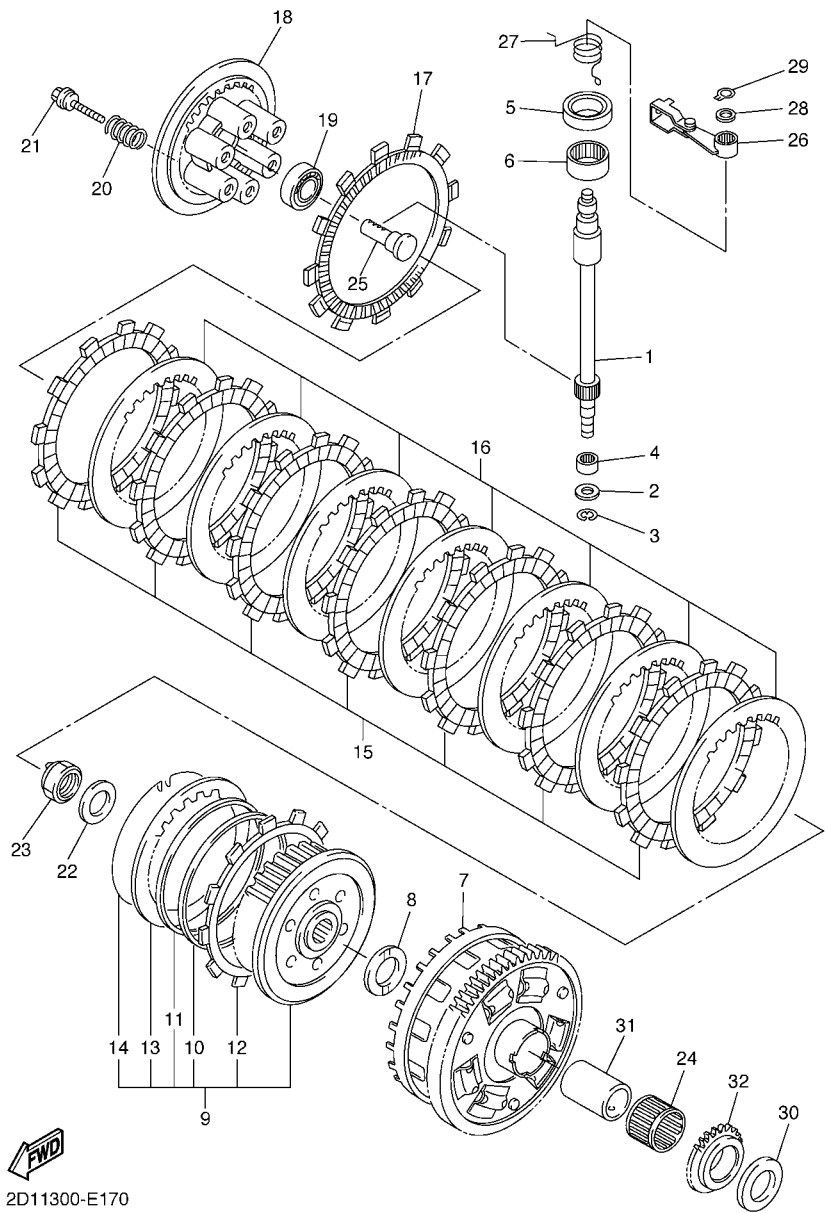

FIG. 16 STARTER

REF. NO.	PART NO.	DESCRIPTION	3C3A	3C3B	3C3C	REMARKS
1	2D1-11537-00	GEAR, DRIVEN	1	1	1	
2	5VY-16155-00	ABSORBER 1	3	3	3	
3	90201-20016	WASHER, PLATE	1	1	1	
4	5VY-11478-00	COLLAR	1	1	1	
5	5VY-15570-00	STARTER CLUTCH ASSY	1	1	1	
6	5VY-15586-00	PLATE, STARTER CLUTCH ASSY	1	1	1	
7	5VY-15515-00	GEAR 3	1	1	1	
8	5VY-11445-00	SPACER	1	1	1	
9	90201-20017	WASHER, PLATE	1	1	1	
10	93210-18397	O-RING	1	1	1	
11	93306-20230	BEARING	1	1	1	
12	5VY-15517-00	GEAR, IDLER 2	1	1	1	
13	5VY-15521-00	SHAFT 1	1	1	1	
14	90201-06589	WASHER, PLATE	1	1	1	
15	90110-06176	BOLT, HEXAGON SOCKET HEAD	1	1	1	



5VY1300-C160



2D11300-E170

FIG. 17 CLUTCH

REF. NO.	PART NO.	DESCRIPTION	3C3A	3C3B	3C3C	REMARKS
1	2D1-16382-00	AXLE, PUSH LEVER	1	1	1	
2	92907-08600	WASHER, PLATE	1	1	1	
3	99001-07600	CIRCLIP	1	1	1	
4	93317-11096	BEARING	1	1	1	
5	93102-15212	OIL SEAL	1	1	1	
6	93315-31502	BEARING	1	1	1	
7	5VY-16150-00	PRIMARY DRIVEN GEAR COMP.	1	1	1	
8	5VY-16154-00	PLATE, THRUST 1	1	1	1	
9	2D1-16370-00	CLUTCH BOSS ASSY	1	1	1	
10	5VY-16384-00	.PLATE, SEAT	1	1	1	
11	5VY-16383-00	.SPRING, CLUTCH BOSS	1	1	1	
12	5VY-16331-00	.PLATE, FRICTION 2	1	1	1	
13	5VY-16325-00	.PLATE, CLUTCH 2	1	1	1	
14	4X7-16385-00	.RING, CLUTCH BOSS	1	1	1	
15	5VY-16321-00	PLATE, FRICTION	7	7	7	
16	5VY-16325-00	PLATE, CLUTCH 2	7	7	7	
17	5VY-16330-00	PLATE, FRICTION 2	1	1	1	
18	5VY-16351-00	PLATE, PRESSURE 1	1	1	1	
19	93306-00304	BEARING	1	1	1	
20	90501-230A0	SPRING, COMPRESSION	6	6	6	
21	90159-06026	SCREW, WITH WASHER	6	6	6	
22	90208-20001	WASHER, CONICAL SPRING	1	1	1	
23	90179-20007	NUT	1	1	1	
24	93310-232R9	BEARING	1	1	1	
25	4XV-16356-01	ROD, PUSH 1	1	1	1	
26	5VY-16340-00	PUSH LEVER ASSY	1	1	1	
27	90508-18051	SPRING, TORSION	1	1	1	

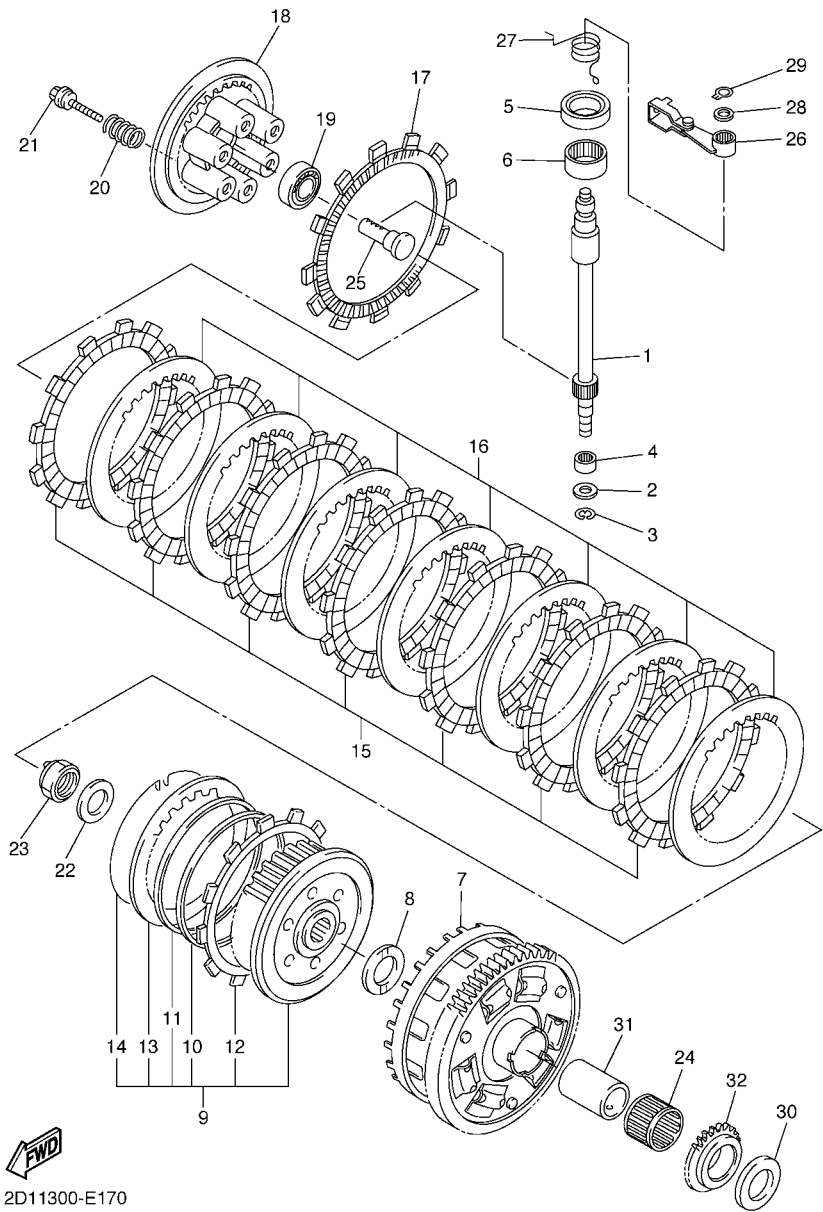

2D11300-E170

FIG. 17 CLUTCH

REF. NO.	PART NO.	DESCRIPTION	3C3A	3C3B	3C3C	REMARKS
28	90201-10029	WASHER, PLATE	1	1	1	
29	99009-10400	CIRCLIP	1	1	1	
30	5VY-16164-00	PLATE, THRUST 2	1	1	1	
31	5VY-16181-00	SPACER 1	1	1	1	
32	5VY-13354-00	SPROCKET, DRIVE	1	1	1	
<hr style="border-top: 1px dashed black;"/>						
<hr style="border-top: 1px dashed black;"/>						
<hr style="border-top: 1px dashed black;"/>						
<hr style="border-top: 1px dashed black;"/>						
<hr style="border-top: 1px dashed black;"/>						
<hr style="border-top: 1px dashed black;"/>						
<hr style="border-top: 1px dashed black;"/>						
<hr style="border-top: 1px dashed black;"/>						
<hr style="border-top: 1px dashed black;"/>						

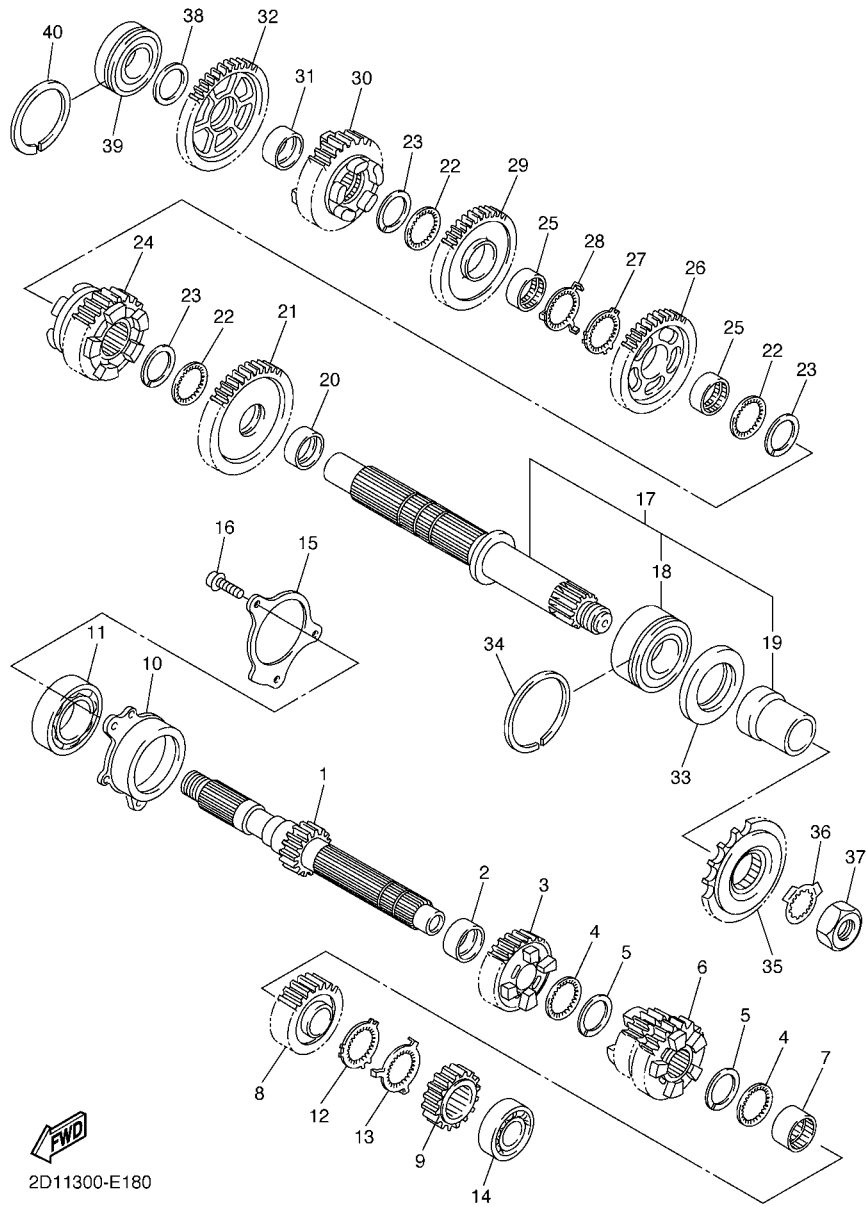

2D11300-E180

FIG. 18 TRANSMISSION

REF. NO.	PART NO.	DESCRIPTION	3C3A	3C3B	3C3C	REMARKS
1	5VY-17411-00	AXLE, MAIN (15T)	1	1	1	
2	90387-28003	COLLAR	1	1	1	
3	2D1-17151-00	GEAR, 5TH PINION (20T)	1	1	1	
4	90209-25011	WASHER	2	2	2	
5	93440-28184	CIRCLIP	2	2	2	
6	2D1-17131-00	GEAR, 3RD PINION (21/23T)	1	1	1	
7	90387-25007	COLLAR	1	1	1	
8	2D1-17161-00	GEAR, 6TH PINION (24T)	1	1	1	
9	2D1-17121-10	GEAR, 2ND PINION (16T)	1	1	1	
10	5VY-15163-00	HOUSING, BEARING 1	1	1	1	
11	93306-20652	BEARING	1	1	1	
12	90214-25004	WASHER, CLAW	1	1	1	
13	90214-25003	WASHER, CLAW	1	1	1	
14	93306-27208	BEARING	1	1	1	
15	5VY-17446-00	PLATE	1	1	1	
16	90110-06164	BOLT, HEXAGON SOCKET HEAD	3	3	3	
17	5VY-17402-00	DRIVE AXLE ASSY	1	1	1	
18	93305-20605	.BEARING	1	1	1	
19	5VY-17442-00	.COLLAR, DISTANCE	1	1	1	
20	90387-31003	COLLAR	1	1	1	
21	2D1-17221-00	GEAR, 2ND WHEEL (33T)	1	1	1	
22	90209-28008	WASHER	3	3	3	
23	93440-31187	CIRCLIP	3	3	3	
24	2D1-17261-00	GEAR, 6TH WHEEL (29T)	1	1	1	
25	90387-28004	COLLAR	2	2	2	
26	5VY-17241-00	GEAR, 4TH WHEEL (35T)	1	1	1	
27	90214-29002	WASHER, CLAW	1	1	1	

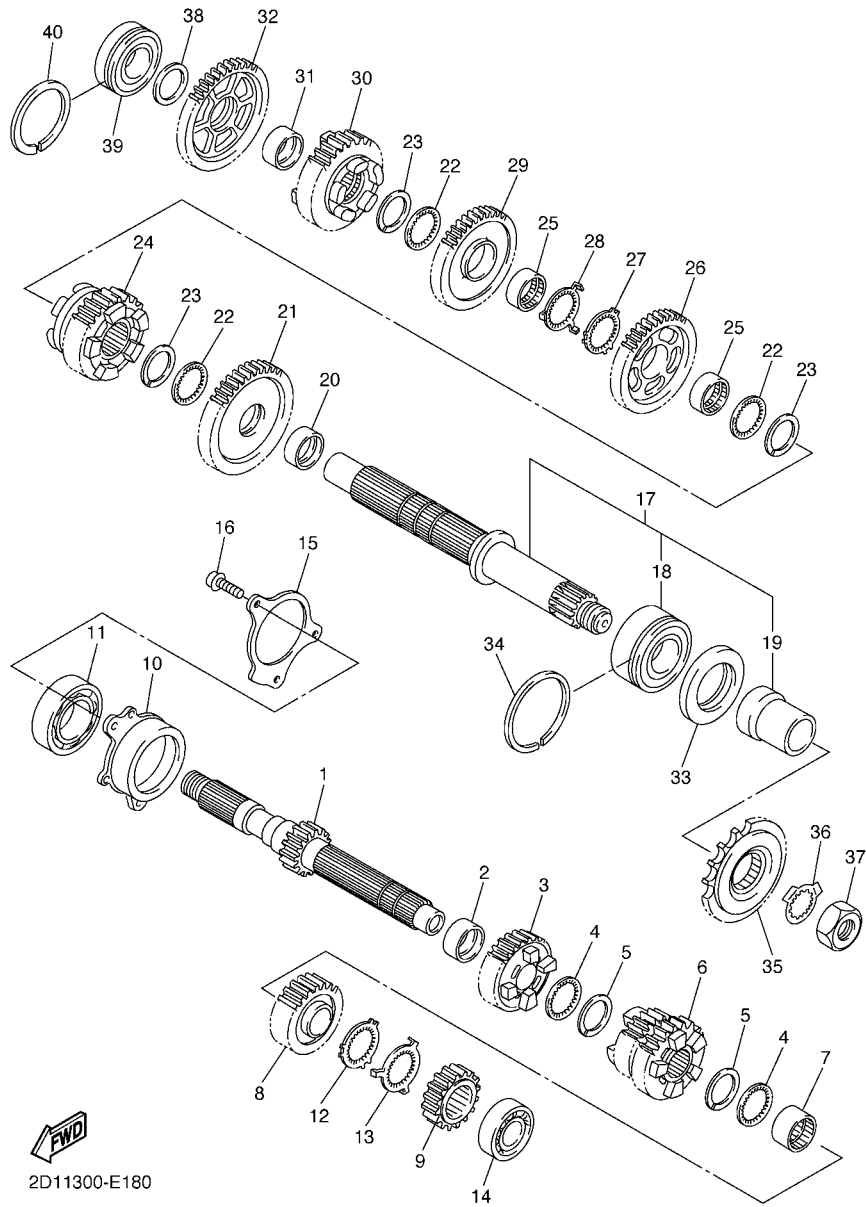

2D11300-E180

FIG. 18 TRANSMISSION

REF. NO.	PART NO.	DESCRIPTION	3C3A	3C3B	3C3C	REMARKS
28	90214-28002	WASHER, CLAW	1	1	1	
29	5VY-17231-00	GEAR, 3RD WHEEL (37T)	1	1	1	
30	2D1-17251-01	GEAR, 5TH WHEEL (27T)	1	1	1	
31	90387-25008	COLLAR	1	1	1	
32	5VY-17211-00	GEAR, 1ST WHEEL (38T)	1	1	1	
33	93102-40330	OIL SEAL	1	1	1	
34	93440-62032	CIRCLIP	1	1	1	
35	3CV-17460-00	SPROCKET, DRIVE (17T)	1	1	1	
36	90215-30233	WASHER, LOCK	1	1	1	
37	90179-22011	NUT	1	1	1	
38	90201-257H0	WASHER, PLATE	1	1	1	
39	93306-205A2	BEARING	1	1	1	
40	93440-52009	CIRCLIP	1	1	1	

FIG. 19 SHIFT CAM & FORK

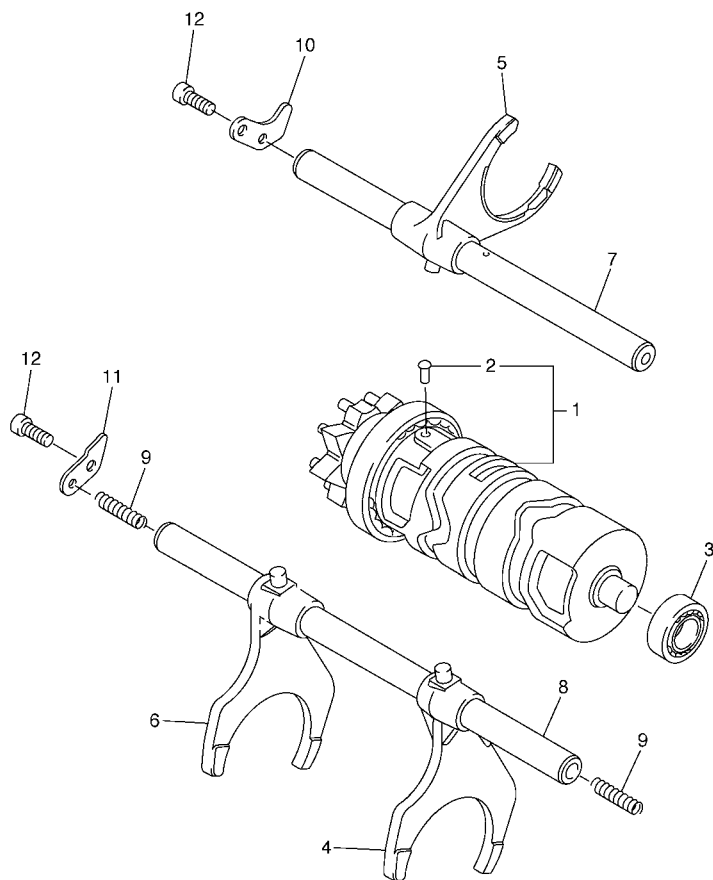

REF. NO.	PART NO.	DESCRIPTION	3C3A	3C3B	3C3C	REMARKS
1	5VY-18540-00	SHIFT CAM ASSY	1	1	1	
2	136-18542-00	.POINT, NEUTRAL	1	1	1	
3	93306-00106	BEARING	1	1	1	
4	2D1-18511-00	FORK, SHIFT 1	1	1	1	
5	2D1-18512-00	FORK, SHIFT 2	1	1	1	
6	5VY-18513-01	FORK, SHIFT 3	1	1	1	
7	5VY-18531-00	BAR, SHIFT FORK GUIDE 1	1	1	1	
8	5VY-18535-00	BAR, SHIFT FORK GUIDE 2	1	1	1	
9	90501-064L1	SPRING, COMPRESSION	2	2	2	
10	5VY-18536-00	STOPPER, SHIFT BAR	1	1	1	
11	5VY-18562-00	PLATE, STOPPER 2	1	1	1	
12	90110-06182	BOLT, HEXAGON SOCKET HEAD	2	2	2	

5VY1300-C190

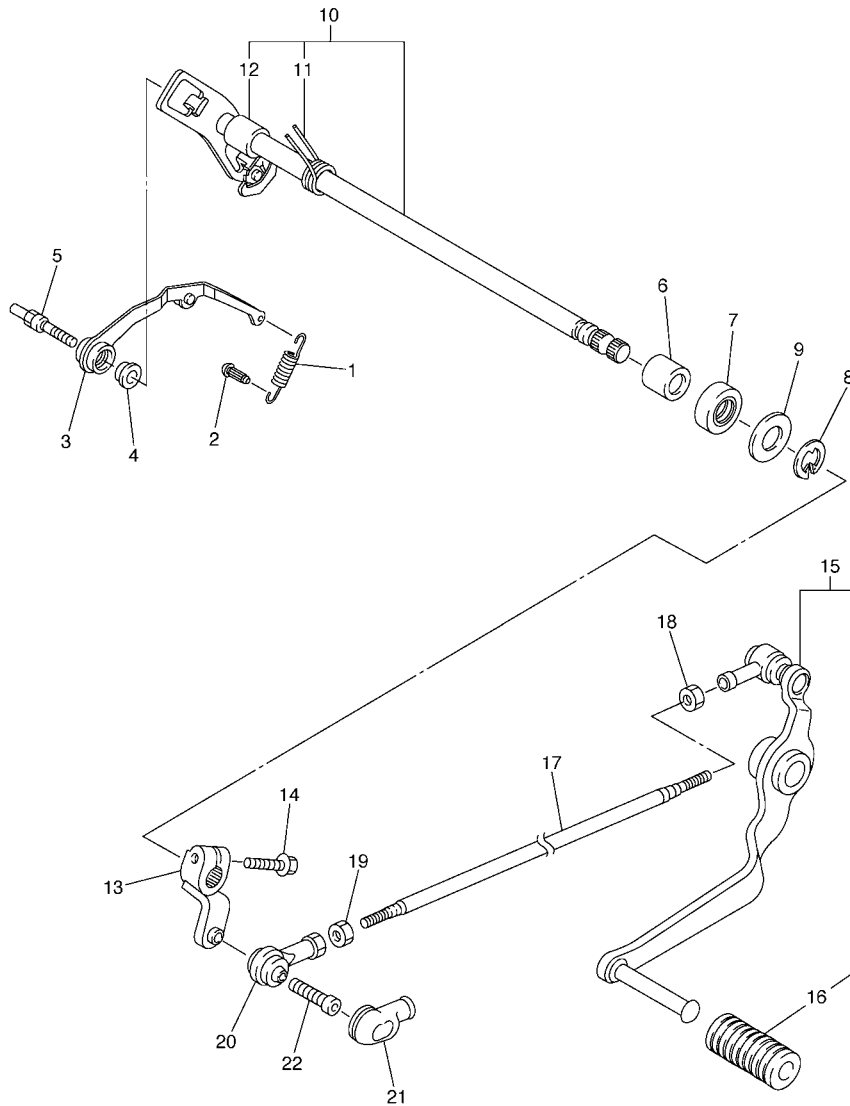
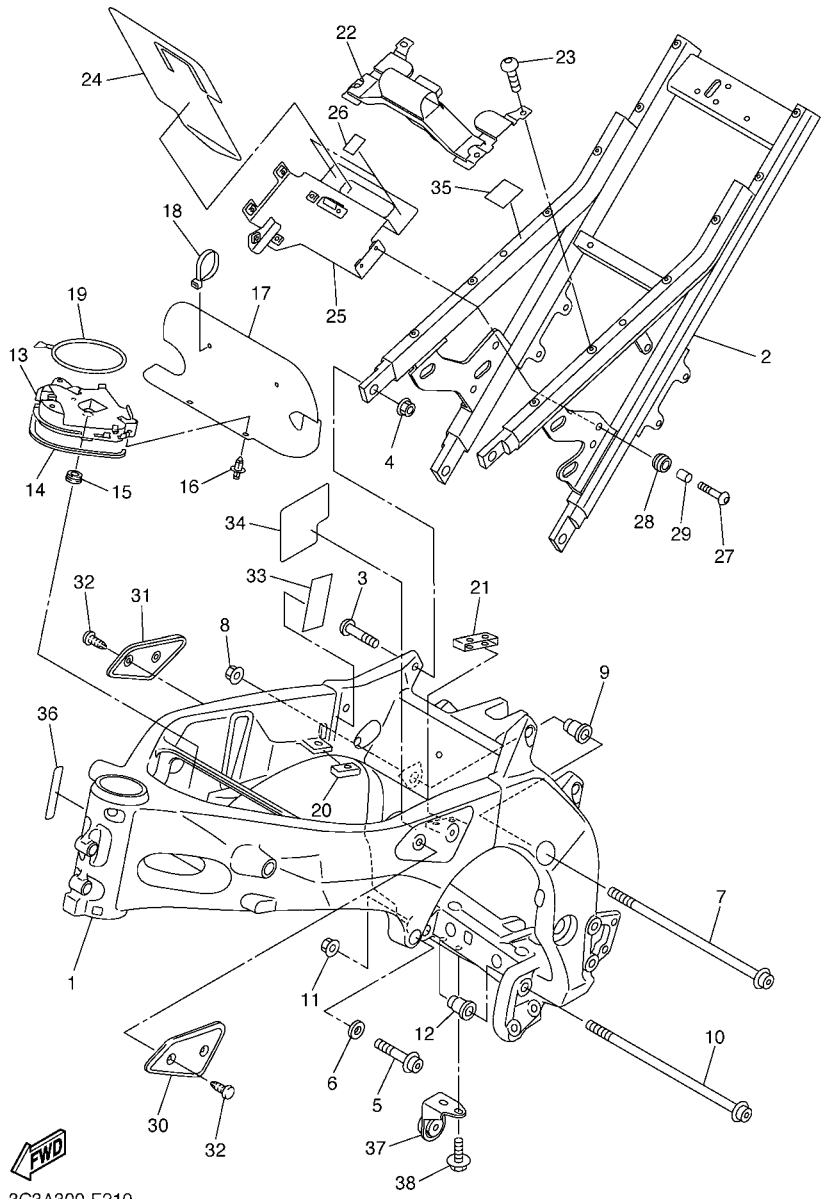

FIG. 20 SHIFT SHAFT

REF. NO.	PART NO.	DESCRIPTION	3C3A	3C3B	3C3C	REMARKS
1	5VY-18144-00	HANGER, SPRING	1	1	1	
2	132-16346-00	HOOK, SPRING	1	1	1	
3	5VY-18140-00	STOPPER LEVER ASSY	1	1	1	
4	90387-0804S	COLLAR	1	1	1	
5	5VY-18127-10	STOPPER, SCREW	1	1	1	
6	93317-11295	BEARING	2	2	2	
7	93102-12106	OIL SEAL (SD 12-22-5 HS)	1	1	1	
8	99002-10600	CIRCLIP	1	1	1	
9	90201-12575	WASHER, PLATE	2	2	2	
10	2D1-18101-00	SHIFT SHAFT ASSY	1	1	1	
11	90508-32020	.SPRING, TORSION	1	1	1	
12	90387-1211D	.COLLAR	1	1	1	
13	2D1-18112-00	ARM, SHIFT	1	1	1	
14	95022-06020	BOLT, FLANGE	1	1	1	
15	2D1-18110-00	SHIFT PEDAL ASSY	1	1	1	
16	5EB-18113-00	.COVER, SHIFT PEDAL	1	1	1	
17	2D1-18115-00	ROD, SHIFT	1	1	1	
18	90170-06228	NUT(COUNTER CLOCKWISE)	1	1	1	
19	95304-06700	NUT	1	1	1	
20	5VX-18116-00	JOINT, ROD 1	1	1	1	
21	5VX-18154-00	COVER, DUST	1	1	1	
22	90111-06019	BOLT,HEX. SOCKET BUTTON	1	1	1	



2D11300-E200



FWD
3C3A300-F210

FIG. 21 FRAME

REF. NO.	PART NO.	DESCRIPTION	3C3A	3C3B	3C3C	REMARKS
1	2D1-21110-00-P0	FRAME COMP.	1	1		MBL2
	2D1-21110-10-P0	FRAME COMP.			1	MBL2
2	2D1-21190-00-P0	REAR FRAME COMP.	1	1	1	MBL2
3	90157-10001	SCREW, PAN HEAD	4	4	4	
4	95604-10200	NUT, SELF-LOCKING	4	4	4	
5	95024-10040	BOLT, FLANGE	2	2	2	
6	90201-10008	WASHER, PLATE	2	2	2	
7	90110-10005	BOLT, HEXAGON SOCKET HEAD	1	1	1	
8	90179-10696	NUT	1	1	1	
9	5EB-21495-00	BOLT, ENGINE ADJUSTING	1	1	1	
10	90110-10005	BOLT, HEXAGON SOCKET HEAD	1	1	1	
11	90179-10696	NUT	1	1	1	
12	5EB-21495-00	BOLT, ENGINE ADJUSTING	1	1	1	
13	2D1-2117N-00	COVER 3	1	1	1	
14	2D1-2174Y-00	DAMPER	1	1	1	
15	90480-01333	GROMMET	1	1	1	
16	90269-06001	RIVET	2	2	2	
17	2D1-2117G-00	PROTECTOR	1	1	1	
18	1UA-82591-00	BAND	2	2	2	
19	3YX-21376-00	BAND, TOOL	1	1	1	
20	2D1-24184-00	DAMPER, LOCATING 4	1	1	1	
21	2D1-24185-00	DAMPER, LOCATING 5	1	1	1	
22	2D1-21345-00	BRACKET, TANK FITTING	1	1	1	
23	90149-06026	SCREW	4	4	4	
24	2D1-24183-00	DAMPER, LOCATING 3	1	1	1	
25	2D1-21287-01	BRACKET, REGULATOR	1	1	1	
26	5YU-21639-00	DAMPER 2	2	2	2	

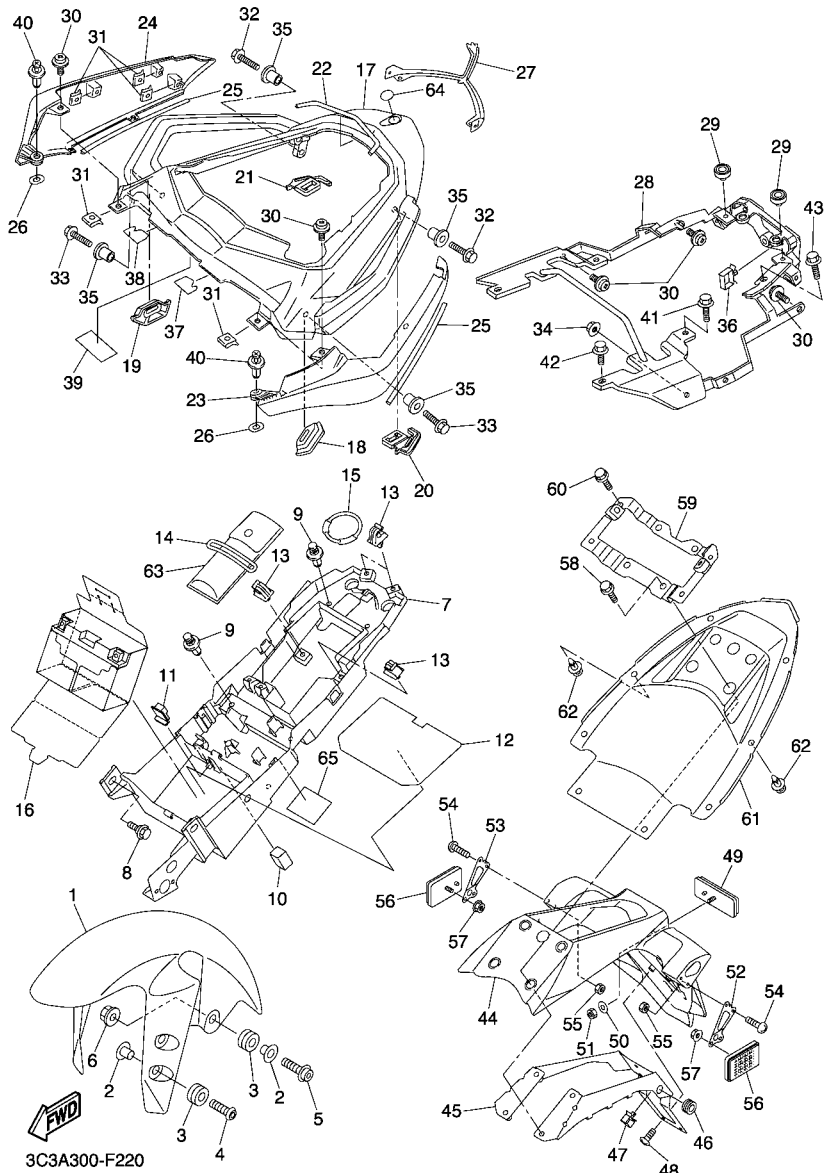
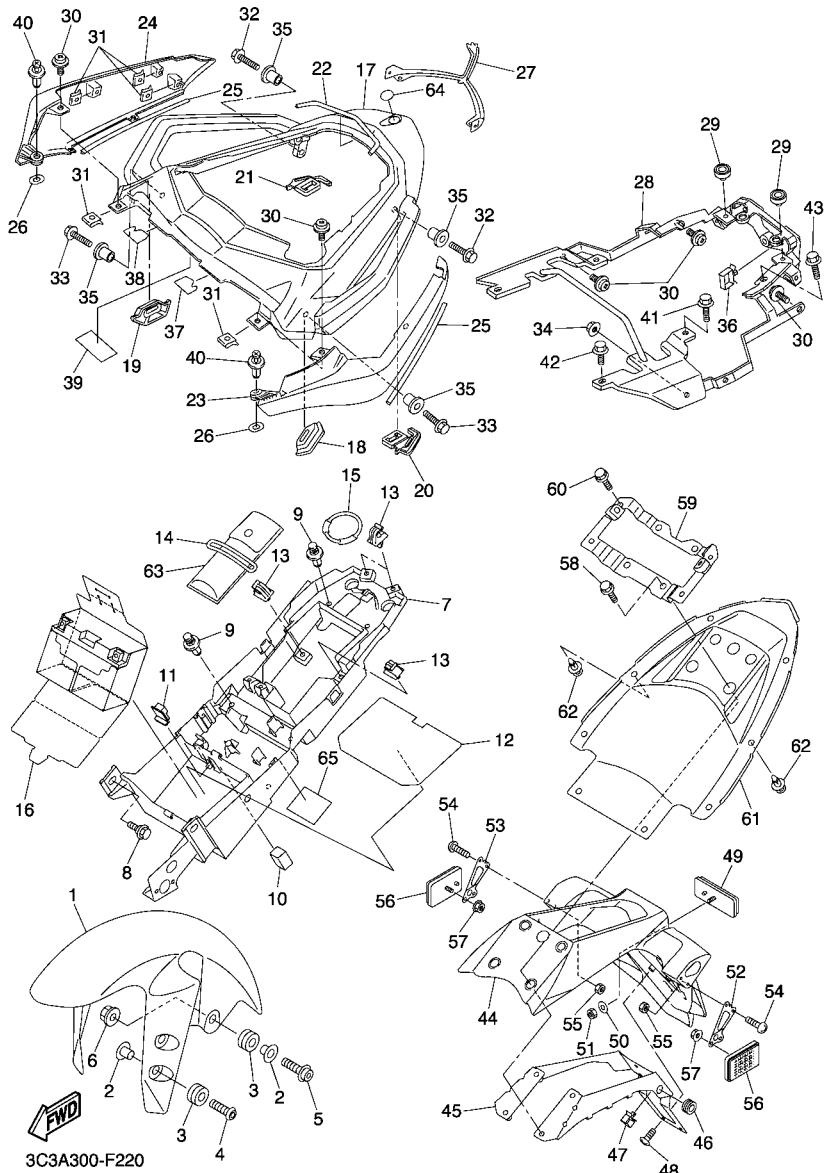

FIG. 22 FENDER

REF. NO.	PART NO.	DESCRIPTION	3C3A	3C3B	3C3C	REMARKS
1	5PW-21511-00-PA	FENDER, FRONT	1	1	1	FOR DPBMU
	5PW-21511-00-P6	FENDER, FRONT	1	1	1	SMX FOR BNM5,DRMK
2	90387-065J6	COLLAR	6	6	6	
3	90480-12072	GROMMET	6	6	6	
4	90111-06043	BOLT,HEX. SOCKET BUTTON	4	4	4	
5	90109-06031	BOLT	2	2	2	
6	95607-06200	NUT, SELF U-FLANGE	2	2	2	
7	2D1-8212B-01	BOX, BATTERY 1	1	1	1	
8	90109-063F1	BOLT	2	2	2	
9	90269-07077	RIVET	4	4	4	
10	2D1-216A2-00	SEAL, 2	1	1	1	
11	2D1-216A3-00	SEAL, 3	1	1	1	
12	2D1-24182-00	DAMPER, LOCATING 2	1	1	1	
13	90464-07259	CLAMP	4	4	4	
14	4XV-21376-00	BAND, TOOL	1	1	1	
15	2D1-21646-00	BAND	1	1	1	
16	2D1-82122-10	SEAT, BATTERY	1	1	1	
17	3C3-24773-00-P0	HANDLE, SEAT	1	1	1	UR FOR DPBMU
	3C3-24773-00-P3	HANDLE, SEAT	1	1	1	UR FOR BNM5
	3C3-24773-00-P2	HANDLE, SEAT	1	1	1	UR FOR DRMK
18	3C3-24723-00	DAMPER, SEAT	1	1	1	
19	3C3-24724-00	DAMPER, SEAT	1	1	1	
20	3C3-24737-00	DAMPER, SEAT	1	1	1	
21	3C3-24747-00	DAMPER, SEAT	1	1	1	
22	3C3-21541-00	DAMPER 1	1	1	1	
23	3C3-2471K-00-P0	COVER, TAIL 1	1	1	1	UR FOR DPBMU
	3C3-2471K-00-P3	COVER, TAIL 1	1	1	1	UR FOR BNM5



3C3A300-F220

FIG. 22 FENDER

REF. NO.	PART NO.	DESCRIPTION	3C3A	3C3B	3C3C	REMARKS
23	3C3-2471K-00-P2	COVER, TAIL 1	1	1	1	UR FOR DRMK
24	3C3-2472K-00-P0	COVER, TAIL 2	1	1	1	UR FOR DPBMU
	3C3-2472K-00-P3	COVER, TAIL 2	1	1	1	UR FOR BNM5
	3C3-2472K-00-P2	COVER, TAIL 2	1	1	1	UR FOR DRMK
25	3C3-2193A-00	PROTECTOR	2	2	2	
26	5PW-2174X-00	DAMPER	2	2	2	
27	3C3-2163A-00	COVER, REAR FENDER 1	1	1	1	
28	3C3-21617-00	BRACKET, FENDER	1	1	1	
29	22W-24741-00	PAD, SEAT	2	2	2	
30	90159-05083	SCREW, WITH WASHER	8	8	8	
31	90183-05024	NUT, SPRING	8	8	8	
32	95822-08025	BOLT, FLANGE	2	2	2	
33	95822-08030	BOLT, FLANGE	2	2	2	
34	95702-08500	NUT, FLANGE	2	2	2	
35	90387-09003	COLLAR	4	4	4	
36	90464-16021	CLAMP	1	1	1	
37	3C3-22825-00	PROTECTOR 1	1	1	1	
38	3C3-22826-00	PROTECTOR 2	1	1	1	
39	2D1-21639-00	DAMPER 2	1	1	1	
40	90269-07076	RIVET	2	2	2	
41	95827-06025	BOLT, FLANGE	2	2	2	
42	95822-06014	BOLT, FLANGE	2	2	2	
43	90105-08447	BOLT, FLANGE	2	2	2	
44	2D1-21629-00	GUARD, MUD	1	1		
	2D1-21629-10	GUARD, MUD			1	
45	2D1-21688-00	BRACKET, REAR STAY	1	1	1	
46	90480-13004	GROMMET	2	2	2	

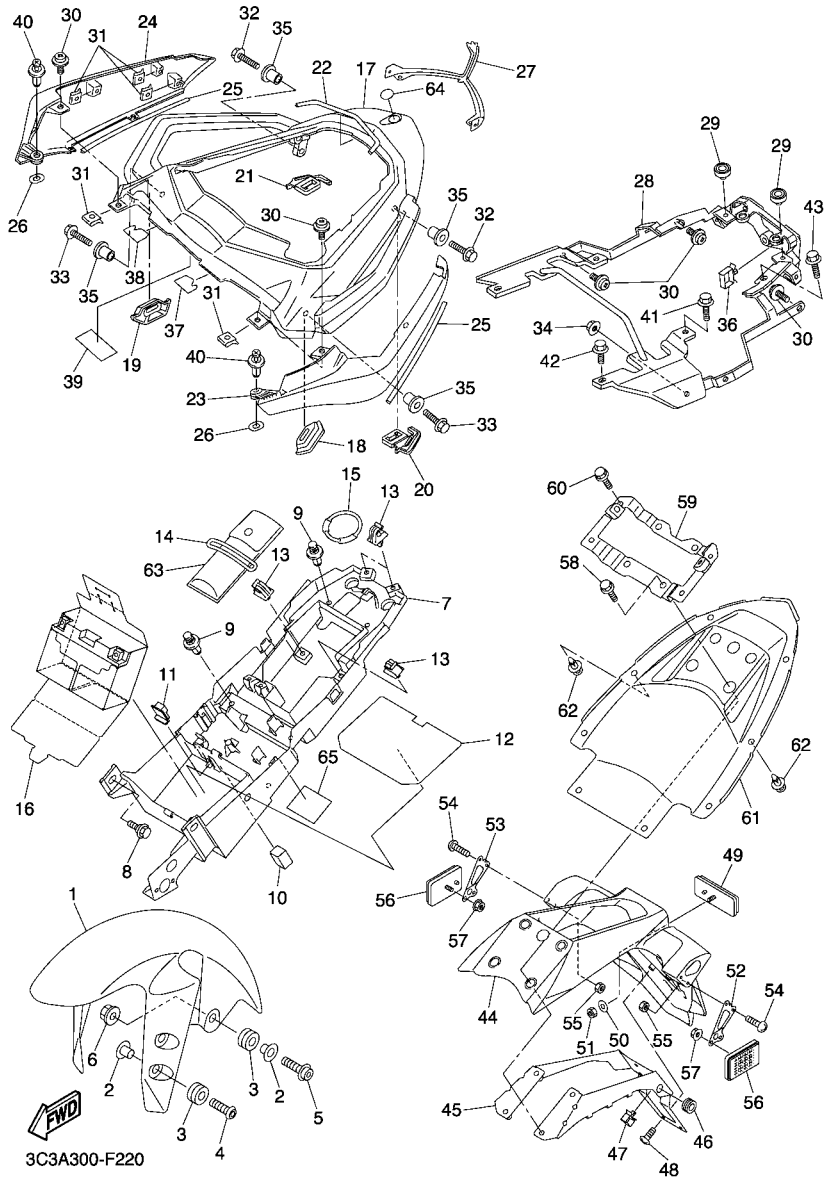
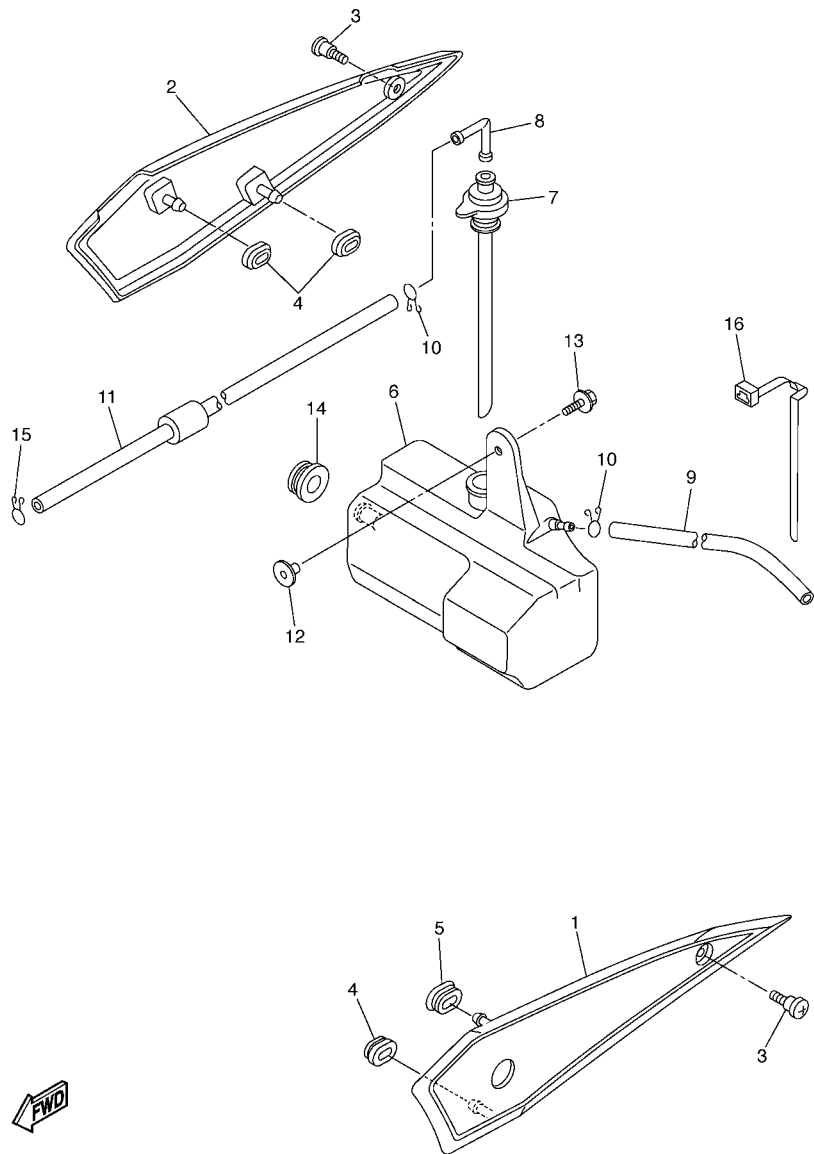

FIG. 22 FENDER

REF. NO.	PART NO.	DESCRIPTION	3C3A	3C3B	3C3C	REMARKS
47	90464-16021	CLAMP	1	1	1	
48	97707-50016	SCREW, TRUSS HEAD TAPPING	6	6	6	
49	3Y6-85130-02	REAR REFLECTOR ASSY	1	1	1	
50	90201-05725	WASHER, PLATE	1	1	1	
51	95607-05100	NUT, U	1	1	1	
52	5VY-21688-00	BRACKET, REAR STAY			1	
53	5VY-21689-00	BRACKET, REAR STAY 2			1	
54	90150-04041	SCREW, ROUND HEAD			4	
55	95607-04100	NUT, U			4	
56	5SL-85110-00	REFLECTOR ASSY			2	
57	95707-05500	NUT, FLANGE			2	
58	95817-08025	BOLT, FLANGE	4	4	4	
59	3C3-21261-00	BRACKET, REAR FENDER	1	1	1	
60	95827-06020	BOLT, FLANGE	4	4	4	
61	3C3-21611-00	FENDER, REAR	1	1	1	
62	90269-07077	RIVET	8	8	8	
63	2D1-28100-00	TOOL KIT	1	1	1	
64	4KN-2836B-00	TUNING FORK MARK	1	1	1	
65	3C3-2118N-00	LABEL		1		

FIG. 23 SIDE COVER



2D11300-E230

REF. NO.	PART NO.	DESCRIPTION	3C3A	3C3B	3C3C	REMARKS
1	2D1-21711-00	COVER, SIDE 1	1	1	1	
2	2D1-21721-00	COVER, SIDE 2	1	1	1	
3	90149-06165	SCREW	2	2	2	
4	90480-01559	GROMMET	3	3	3	
5	2D1-21719-00	GROMMET	1	1	1	
6	2D1-21871-00	TANK, RECOVERY	1	1	1	
7	5VY-21875-00	CAP	1	1	1	
8	26H-21828-00	ELBOW	1	1	1	
9	90445-08022	HOSE	1	1	1	
10	90467-08075	CLIP	2	2	2	
11	90445-087K6	HOSE (L700)	1	1	1	
12	90387-062M9	COLLAR	1	1	1	
13	90119-06228	BOLT, WITH WASHER	1	1	1	
14	90480-20001	GROMMET	1	1	1	
15	90467-08075	CLIP	1	1	1	
16	90464-07M40	CLAMP	1	1	1	

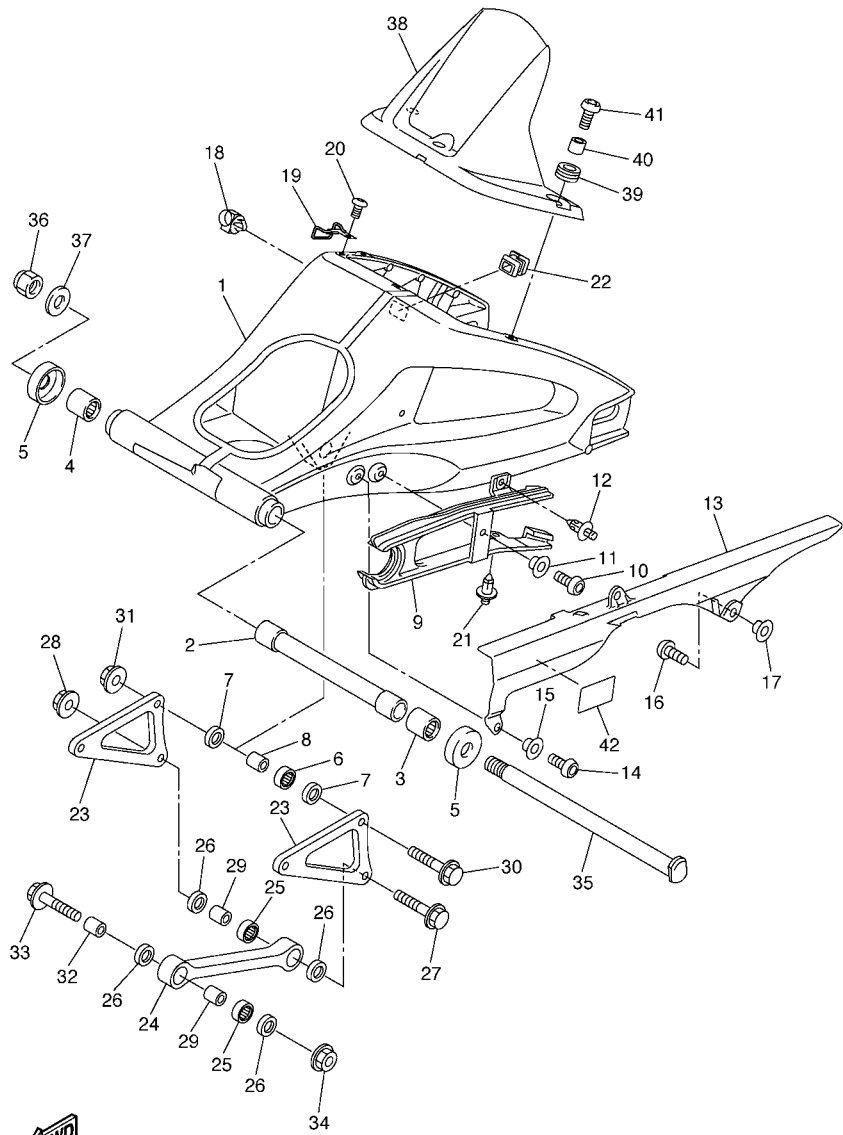

2D11300-E240

FIG. 24 REAR ARM

REF. NO.	PART NO.	DESCRIPTION	3C3A	3C3B	3C3C	REMARKS
1	2D1-22110-11	REAR ARM COMP.	1	1	1	
2	2D1-22184-00	BUSH	1	1	1	
3	93317-42599	BEARING	1	1	1	
4	93315-42536	BEARING	1	1	1	
5	5JJ-22128-00	COVER, THRUST 1	2	2	2	
6	93315-41762	BEARING	1	1	1	
7	93109-17071	OIL SEAL	2	2	2	
8	90387-1012A	COLLAR	1	1	1	
9	2D1-22151-00	SEAL, GUARD	1	1	1	
10	92012-06014	BOLT, BUTTON HEAD	1	1	1	
11	90387-06130	COLLAR	1	1	1	
12	90269-07007	RIVET	1	1	1	
13	5SL-22311-00	CASE, CHAIN	1	1	1	
14	92012-06014	BOLT, BUTTON HEAD	1	1	1	
15	90387-06130	COLLAR	1	1	1	
16	90110-06102	BOLT, HEXAGON SOCKET HEAD	2	2	2	
17	90387-06009	COLLAR	2	2	2	
18	90464-17003	CLAMP	1	1	1	
19	2D1-25887-00	HOLDER, BRAKE HOSE	1	1	1	
20	92012-06014	BOLT, BUTTON HEAD	1	1	1	
21	90269-07008	RIVET	1	1	1	
22	2D1-22117-00	CAP	1	1	1	
23	2D1-2217A-00	ARM, RELAY	2	2	2	
24	2D1-2217M-00	ARM 1	1	1	1	
25	93315-31758	BEARING	2	2	2	
26	93109-17071	OIL SEAL	4	4	4	
27	90105-10030	BOLT, FLANGE	1	1	1	

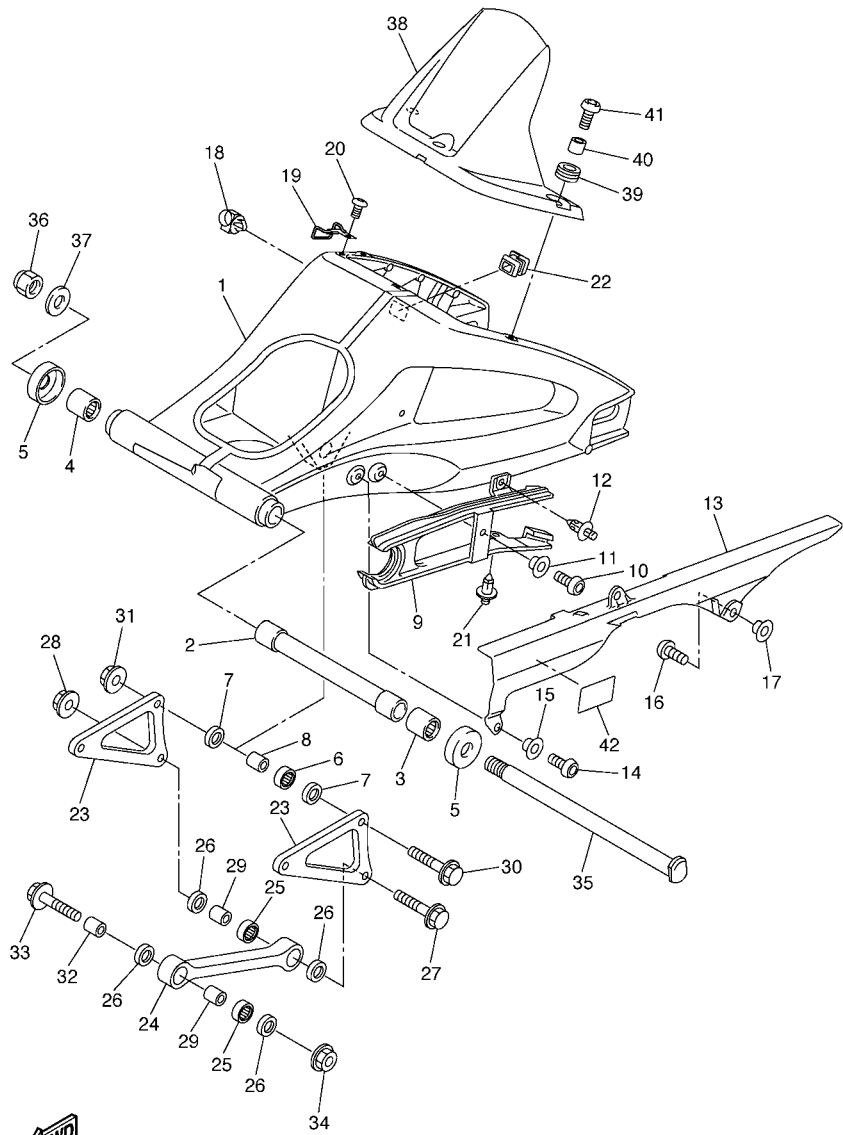

2D11300-E240

FIG. 24 REAR ARM

REF. NO.	PART NO.	DESCRIPTION	3C3A	3C3B	3C3C	REMARKS
28	95607-10200	NUT, U FLANGE	1	1	1	
29	90387-1012A	COLLAR	2	2	2	
30	90105-10030	BOLT, FLANGE	2	2	2	
31	95607-10200	NUT, U FLANGE	2	2	2	
32	90387-10043	COLLAR	1	1	1	
33	90105-10323	BOLT, FLANGE	1	1	1	
34	95607-10200	NUT, U FLANGE	1	1	1	
35	2D1-22141-00	SHAFT, PIVOT	1	1	1	
36	90185-18167	NUT, SELF-LOCKING	1	1	1	
37	90201-18013	WASHER, PLATE	1	1	1	
38	2D1-21650-00	REAR FENDER COMP.	1	1	1	
39	90480-12003	GROMMET	3	3	3	
40	90387-0600V	COLLAR	3	3	3	
41	90149-06302	SCREW	3	3	3	
42	5VY-21668-00	LABEL, TIRE	1	1	1	

D9

FIG. 26 STEERING

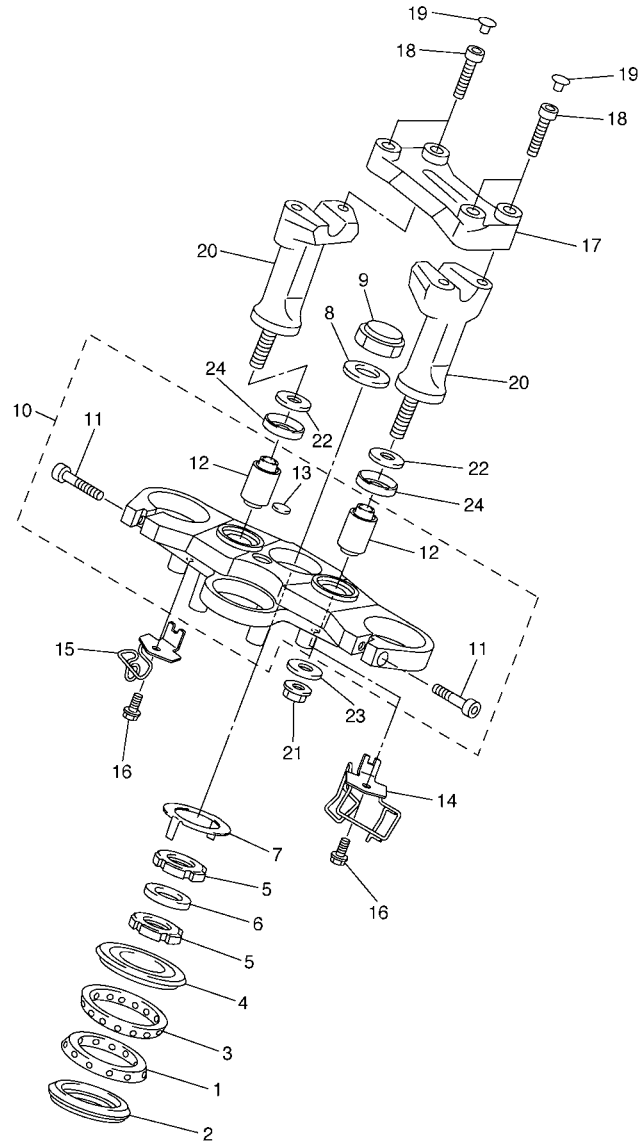

REF. NO.	PART NO.	DESCRIPTION	3C3A	3C3B	3C3C	REMARKS
1	93399-99957	BEARING	1	1	1	
2	3FV-23462-00	SEAL, STEERING	1	1	1	
3	93399-99932	BEARING	1	1	1	
4	4XV-23415-01	COVER, BALL RACE 1	1	1	1	
5	90179-30691	NUT	2	2	2	
6	90202-30235	WASHER, PLATE	1	1	1	
7	4XV-23418-00	WASHER, SPECIAL	1	1	1	
8	90201-281U8	WASHER, PLATE	1	1	1	
9	90176-28083	NUT, CROWN	1	1	1	
10	2D1-23405-00	CROWN, HANDLE ASSY	1	1	1	
11	91314-08030	.BOLT	2	2	2	
12	3VD-23434-00	.HOLDER, DAMPER	2	2	2	
13	4XV-2341B-00	.EMBLEM	1	1	1	
14	3C3-23318-00	HOLDER, CABLE 1	1	1	1	
15	3C3-23319-00	HOLDER, CABLE 2	1	1	1	
16	90105-06050	BOLT, FLANGE	2	2	2	
17	2D1-23441-00	HOLDER, HANDLE UPPER	1	1	1	
18	91317-08030	BOLT	4	4	4	
19	90338-08163	PLUG	4	4	4	
20	2D1-23442-00	HOLDER, HANDLE LOWER	2	2	2	
21	95607-10200	NUT, U FLANGE	2	2	2	
22	92907-10200	WASHER, PLAIN	2	2	2	
23	90201-10141	WASHER, PLATE	2	2	2	
24	5YU-23445-00	DAMPER	2	2	2	



3C31300-E260

FIG. 27 FRONT FORK

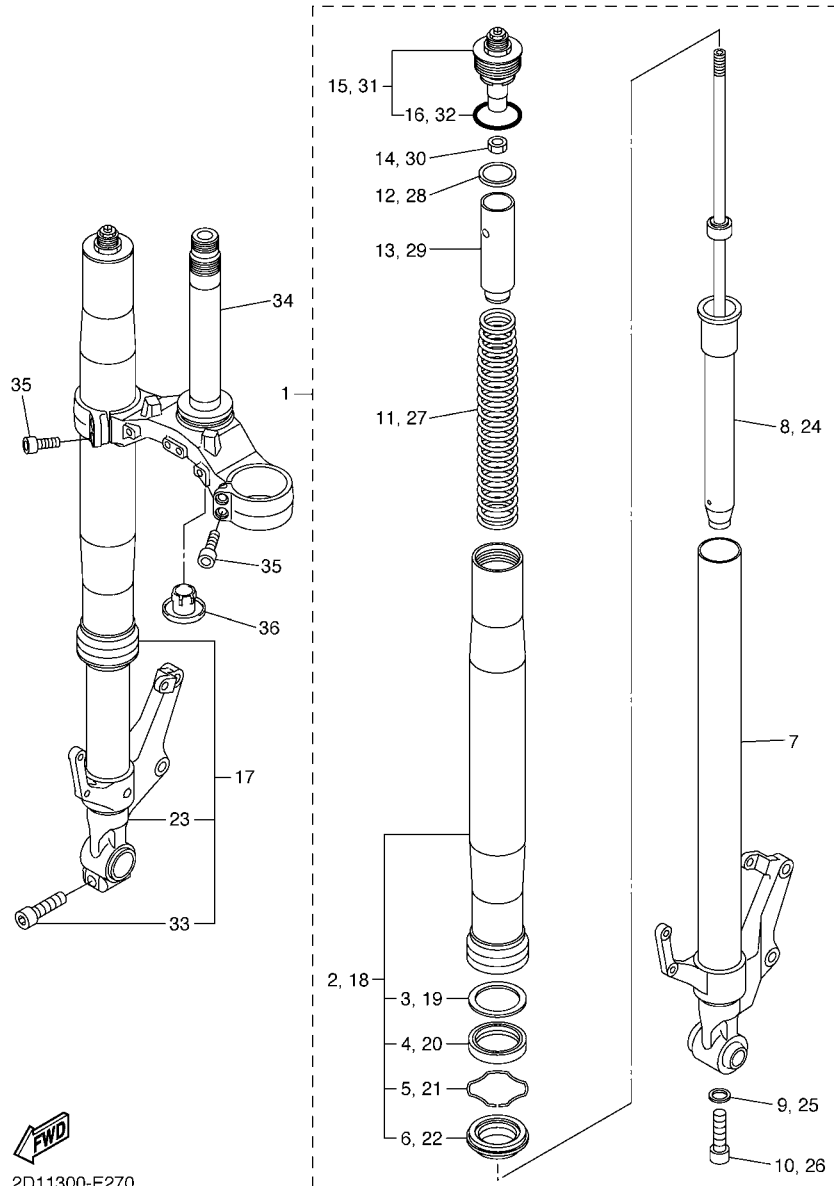

2D11300-E270

REF. NO.	PART NO.	DESCRIPTION	3C3A	3C3B	3C3C	REMARKS
1	2D1-23102-11	FRONT FORK ASSY (L.H)	1	1	1	
2	2D1-23136-10	.TUBE, OUTER (RIGHT)	1	1	1	
3	4V4-23146-L0	..WASHER, OIL SEAL	1	1	1	
4	4PU-23145-01	..OIL SEAL	1	1	1	
5	4V4-23153-L0	..RING, SNAP	1	1	1	
6	4PU-23144-00	..SEAL, DUST	1	1	1	
7	2D1-23110-00	.INNER TUBE COMP.1	1	1	1	
8	2D1-23170-11	.CYLINDER COMP., FRONT FORK	1	1	1	
9	509-23158-L0	.GASKET	1	1	1	
10	3D8-23181-00	.BOLT, HEXAGON SOCKET HEAD	1	1	1	
11	2D1-23141-00	.SPRING, FRONT FORK	1	1	1	
12	5VY-12277-00	.WASHER	1	1	1	
13	5VY-23118-00	.SPACER	1	1	1	
14	3LC-23357-00	.NUT	1	1	1	
15	2D1-23111-10	.BOLT, CAP	1	1	1	
16	3XJ-23147-L0	..O-RING	1	1	1	
17	2D1-23103-11	FRONT FORK ASSY (R.H)	1	1	1	
18	2D1-23136-10	.TUBE, OUTER (RIGHT)	1	1	1	
19	4V4-23146-L0	..WASHER, OIL SEAL	1	1	1	
20	4PU-23145-01	..OIL SEAL	1	1	1	
21	4V4-23153-L0	..RING, SNAP	1	1	1	
22	4PU-23144-00	..SEAL, DUST	1	1	1	
23	2D1-23120-00	.INNER TUBE COMP.2	1	1	1	
24	2D1-23170-01	.CYLINDER COMP., FRONT FORK	1	1	1	
25	509-23158-L0	.GASKET	1	1	1	
26	3D8-23181-00	.BOLT, HEXAGON SOCKET HEAD	1	1	1	
27	2D1-23141-00	.SPRING, FRONT FORK	1	1	1	

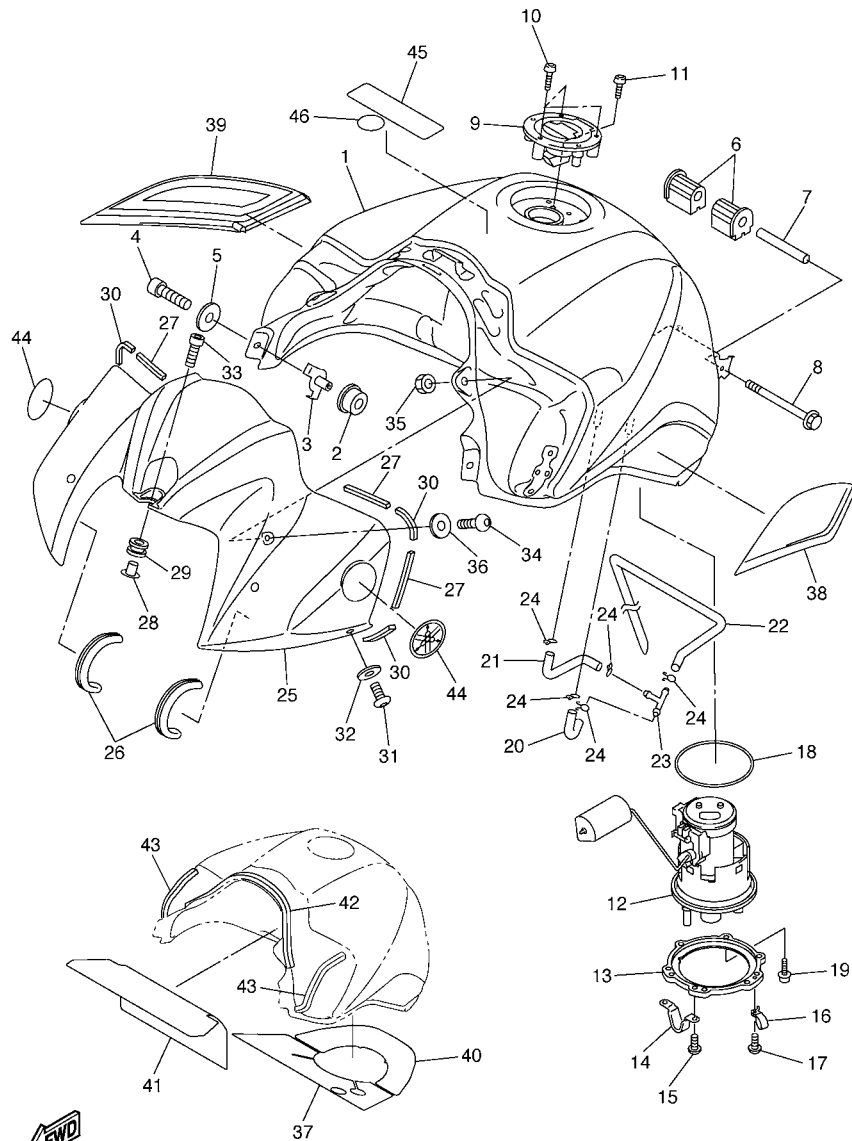

2D11300-E280

FIG. 28 FUEL TANK

REF. NO.	PART NO.	DESCRIPTION	3C3A	3C3B	3C3C	REMARKS
1	2D1-YK241-00-P3	FUEL TANK COMP.	1	1	1	UR FOR DPBMU
	2D1-YK241-00-P5	FUEL TANK COMP.	1	1	1	UR FOR BNM5
	2D1-YK241-00-P4	FUEL TANK COMP.	1	1	1	UR FOR DRMK
2	5VY-24181-00	DAMPER, LOCATING 1	2	2	2	
3	2D1-2412G-00	COLLAR	2	2	2	
4	91317-06016	BOLT	2	2	2	
5	90201-060A3	WASHER, PLATE	2	2	2	
6	5VX-24181-00	DAMPER, LOCATING 1	2	2	2	
7	90387-061W6	COLLAR	1	1	1	
8	91317-06090	BOLT	1	1	1	
9	5JJ-24602-00	CAP ASSY	1	1	1	
10	90110-05112	BOLT, HEXAGON SOCKET HEAD	3	3	3	
11	91317-05010	BOLT	1	1	1	
12	2D1-13907-01	FUEL PUMP COMP.	1	1	1	
13	2D1-24491-00	BRACKET, FUEL PUMP	1	1	1	
14	2D1-24192-00	BRACKET, FUEL TANK 2	1	1	1	
15	98907-05008	SCREW, BIND	2	2	2	
16	90461-10010	CLAMP	1	1	1	
17	90154-05012	SCREW, BINDING	1	1	1	
18	5JW-24486-00	O-RING	1	1	1	
19	90110-05014	BOLT, HEXAGON SOCKET HEAD	6	6	6	
20	2D1-24315-00	PIPE 5	1	1	1	
21	2D1-24316-00	PIPE 6	1	1	1	
22	2D1-24317-00	PIPE 7	1	1	1	
23	90413-07007	WAY 3	1	1	1	
24	90467-09006	CLIP	5	5	5	
25	3C3-2171A-00-P0	COVER, TOP	1	1	1	FOR DPBMU

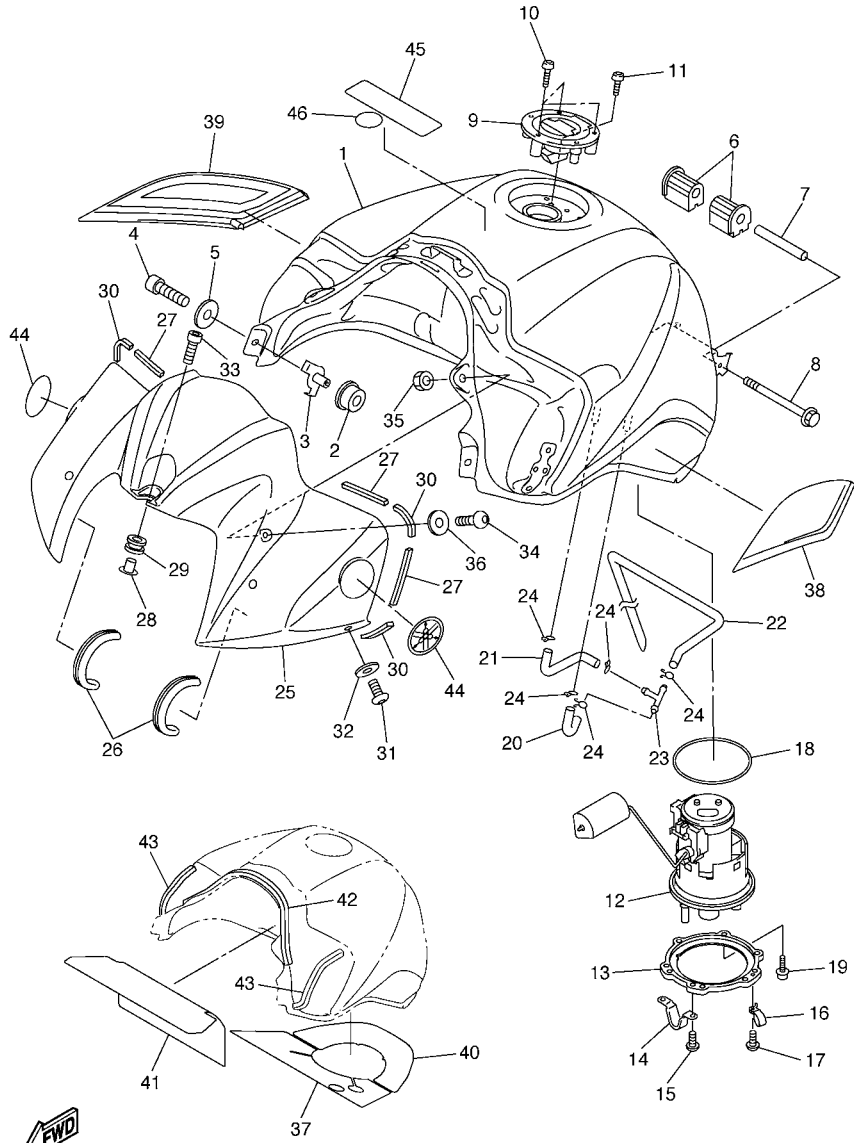

2D11300-E280

FIG. 28 FUEL TANK

REF. NO.	PART NO.	DESCRIPTION	3C3A	3C3B	3C3C	REMARKS
25	3C3-2171A-00-P3	COVER, TOP	1	1	1	SMX FOR BNM5,DRMK
26	2D1-28345-01	MOLE 1	2	2	2	
27	4XV-2834E-00	DAMPER 3	4	4	4	
28	90387-062Y6	COLLAR	1	1	1	
29	90480-12314	GROMMET	1	1	1	
30	2D1-24181-00	DAMPER, LOCATING 1	4	4	4	
31	90111-05019	BOLT,HEX. SOCKET BUTTON	2	2	2	
32	90202-05224	WASHER, PLATE	2	2	2	
33	90110-06233	BOLT, HEXAGON SOCKET HEAD	1	1	1	
34	90111-05024	BOLT,HEX. SOCKET BUTTON	2	2	2	
35	90179-05003	NUT	2	2	2	
36	90202-05088	WASHER, PLATE	2	2	2	
37	2D1-2414N-00	DAMPER, PLATE 4	1	1	1	
38	2D1-24106-00	TANK SIDE COVER ASSY 1	1	1	1	
39	2D1-24108-00	TANK SIDE COVER ASSY 2	1	1	1	
40	2D1-2414K-00	DAMPER, PLATE 3	1	1	1	
41	2D1-2414H-00	DAMPER, PLATE 1	1	1	1	
42	2D1-2414P-00	DAMPER, PLATE 5	1	1	1	
43	2D1-2414R-00	DAMPER, PLATE 6	2	2	2	
44	5SL-2413B-00	EMBLEM	2	2	2	
45	5PA-21568-00	LABEL, WARNING	1	1	1	
46	3ME-2415E-01	LABEL, CAUTION	1	1		

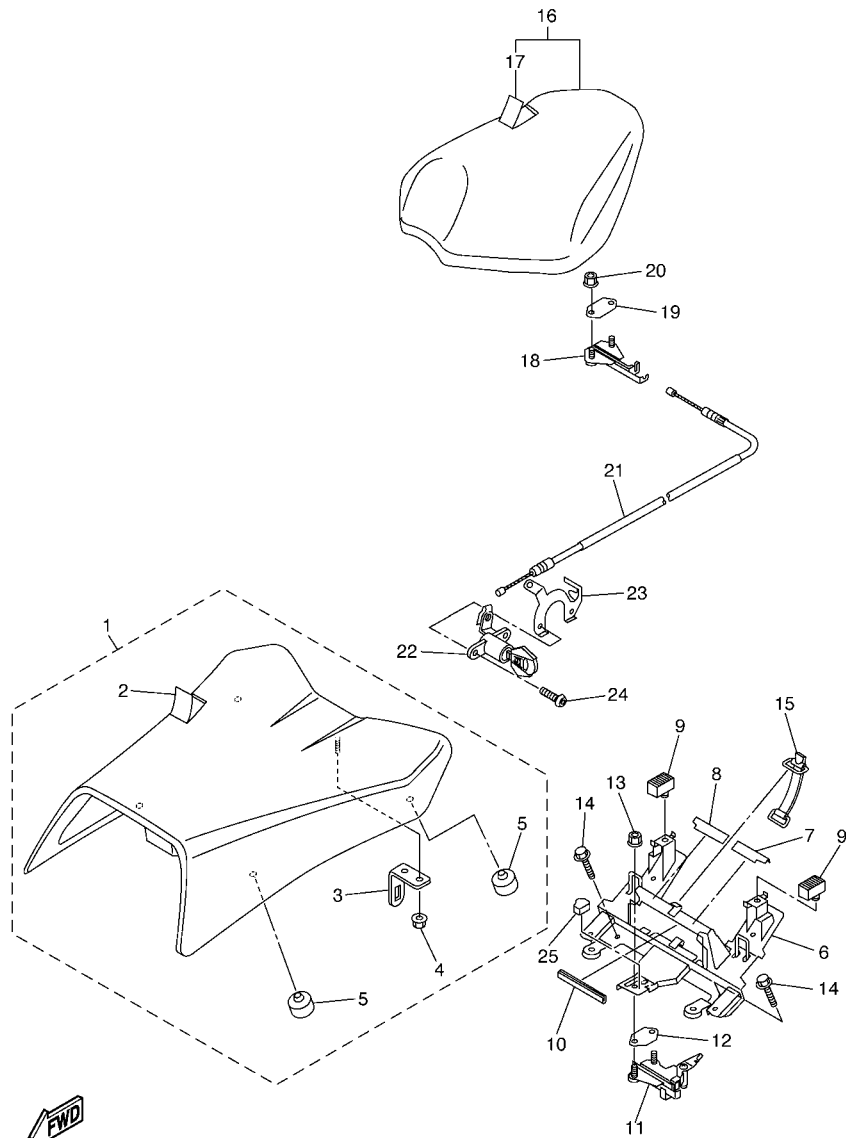

3C3D100-F290

FIG. 29 SEAT

REF. NO.	PART NO.	DESCRIPTION	3C3A	3C3B	3C3C	REMARKS
1	2D1-24710-00	SINGLE SEAT ASSY	1	1	1	
2	2D1-24711-00	.COVER, SINGLE SEAT	1	1	1	
3	4HM-24728-00	.BRACKET, SEAT	1	1	1	
4	95607-06200	.NUT, SELF U-FLANGE	1	1	1	
5	278-27114-00	.STOPPER, MAIN STAND	4	4	4	
6	3C3-21341-01	BRACKET, SEAT 1	1	1	1	
7	2D1-2476U-00	PROTECTOR,1	1	1	1	
8	2D1-2476V-00	PROTECTOR,2	1	1	1	
9	3C3-24741-00	PAD, SEAT	2	2	2	
10	2D1-24785-00	MOLD, SEAT	1	1	1	
11	2D1-24780-02	SEAT LOCK ASSY	1	1	1	
12	4BP-24792-00	PLATE	1	1	1	
13	95702-06500	NUT, FLANGE	2	2	2	
14	95827-06020	BOLT, FLANGE	2	2	2	
15	18G-82131-00	BAND, BATTERY	1	1	1	
16	3C3-24750-00	TANDEM SEAT ASSY	1	1	1	
17	3C3-24751-00	.COVER, TANDEM SEAT	1	1	1	
18	4BP-24780-00	SEAT LOCK ASSY	1	1	1	
19	4BP-24792-00	PLATE	1	1	1	
20	95702-06500	NUT, FLANGE	2	2	2	
21	2D1-2478E-00	CABLE, SEAT LOCK	1	1	1	
22	2TV-W2470-00	SEAT LOCK ASSY	1	1	1	
23	4XV-2117K-00	STAY, LOCK	1	1	1	
24	90149-06006	SCREW	2	2	2	
25	2D1-24665-00	DAMPER	1	1	1	

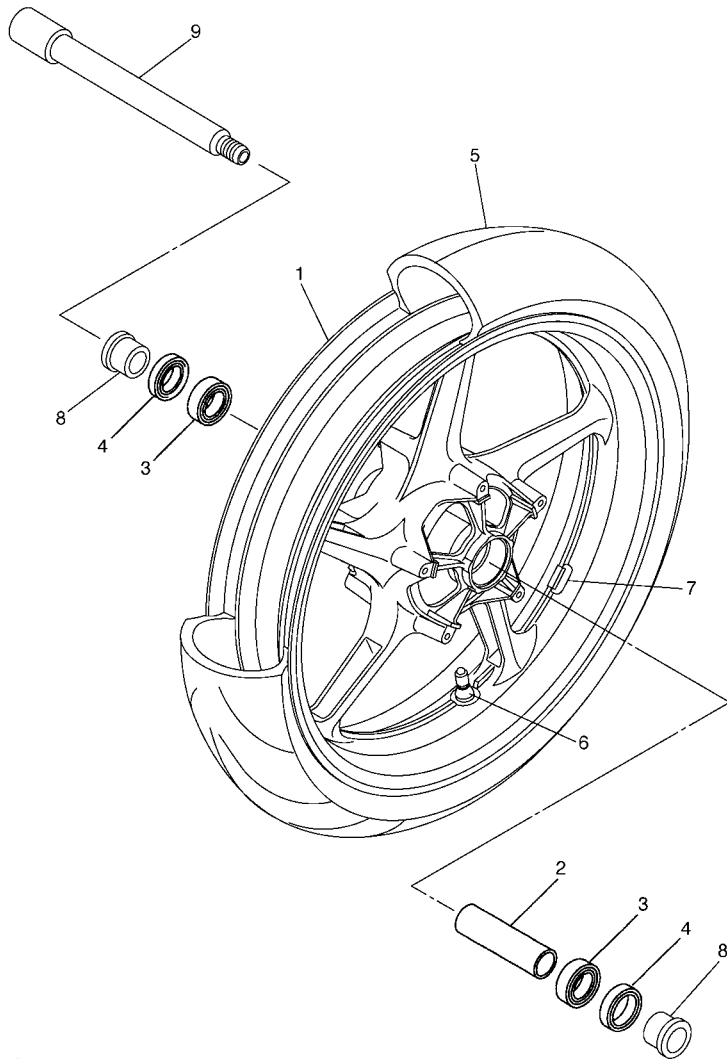
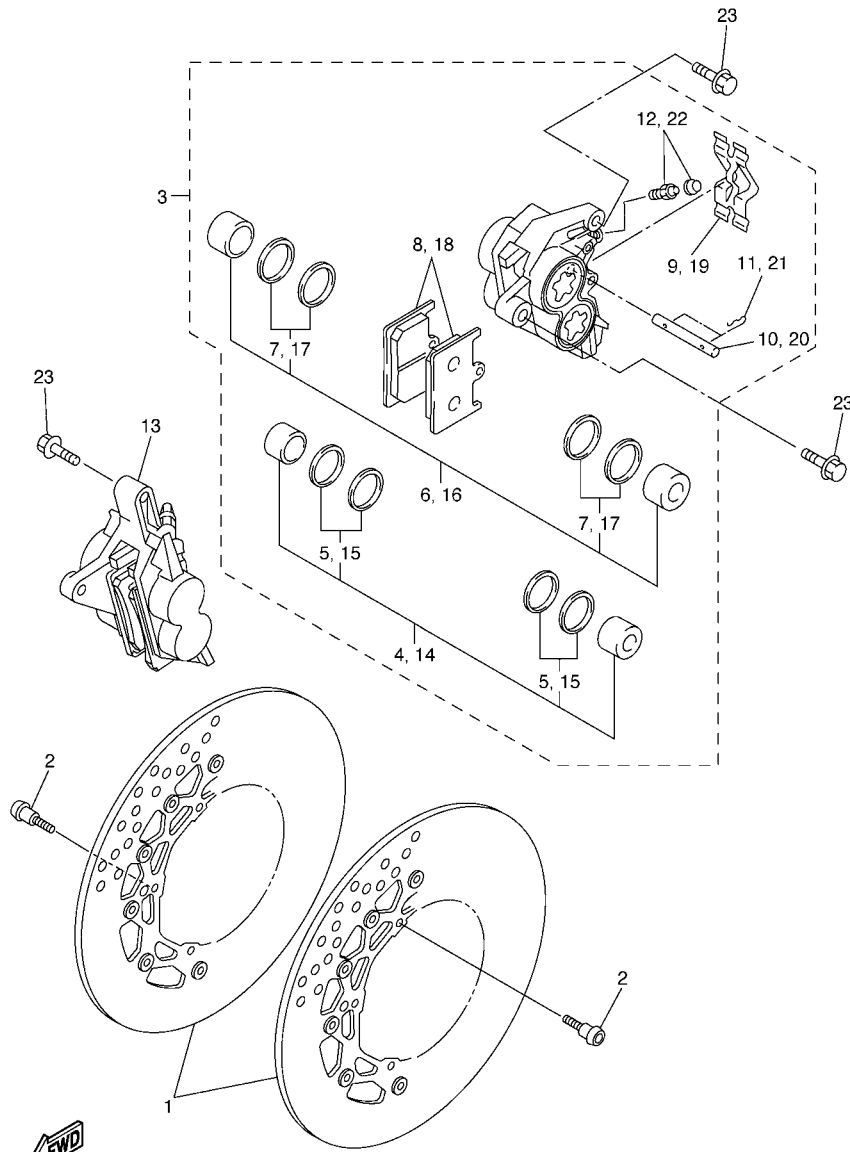

FIG. 30 FRONT WHEEL

REF. NO.	PART NO.	DESCRIPTION	3C3A	3C3B	3C3C	REMARKS
1	5VY-25168-00-98	CAST WHEEL, FRONT	1	1	1	LGB
2	4XV-25117-00	SPACER, BEARING	1	1	1	
3	93306-00420	BEARING	2	2	2	
4	93106-28043	OIL SEAL	2	2	2	
5	94112-17094	TIRE(120/70 ZR17M/C58W D221FA)	1	1	1	UR DUNLOP
		TIRE(120/70 ZR17M/C 58W PILOT)	1	1	1	UR LM MICHELIN
6	93900-00030	VALVE, RIM (TR412)	1	1	1	TAIHEIYO
7	5MT-25398-00	BALANCER, WHEEL (10G)	1	1	1	UN
	5MT-25398-10	BALANCER, WHEEL (20G)	1	1	1	UN
	5MT-25398-20	BALANCER, WHEEL (30G)	1	1	1	UN
8	90387-22002	COLLAR	2	2	2	
9	4XV-25181-10	AXLE, WHEEL	1	1	1	



2D14300-F300



2D11300-E310

FIG. 31 FRONT BRAKE CALIPER

REF. NO.	PART NO.	DESCRIPTION	3C3A	3C3B	3C3C	REMARKS
1	5D0-2581T-00	DISK BRAKE ASSY	2	2	2	
2	90149-06043	SCREW	10	10	10	
3	2D1-2580T-00	CALIPER ASSY (LEFT)	1	1	1	
4	4SV-W0057-00	.PISTON ASSY, CALIPER	1	1	1	
5	3MA-W0047-10	..CALIPER SEAL KIT	1	1	1	
6	4SV-W0057-10	.PISTON ASSY, CALIPER	1	1	1	
7	3GM-W0047-10	..CALIPER SEAL KIT	1	1	1	
8	5SL-W0045-00	.BRAKE PAD KIT	1	1	1	
9	4SV-25919-00	.SUPPORT, PAD	1	1	1	
10	4SV-25924-00	.PIN, PAD	1	1	1	
11	3GM-25925-00	.CLIP	2	2	2	
12	1J3-W0048-00	.BLEED SCREW KIT	1	1	1	
13	2D1-2580U-00	CALIPER ASSY (RIGHT)	1	1	1	
14	4SV-W0057-00	.PISTON ASSY, CALIPER	1	1	1	
15	3MA-W0047-10	..CALIPER SEAL KIT	1	1	1	
16	4SV-W0057-10	.PISTON ASSY, CALIPER	1	1	1	
17	3GM-W0047-10	..CALIPER SEAL KIT	1	1	1	
18	5SL-W0045-00	.BRAKE PAD KIT	1	1	1	
19	4SV-25919-00	.SUPPORT, PAD	1	1	1	
20	4SV-25924-00	.PIN, PAD	1	1	1	
21	3GM-25925-00	.CLIP	2	2	2	
22	1J3-W0048-00	.BLEED SCREW KIT	1	1	1	
23	90105-10638	BOLT, FLANGE	4	4	4	

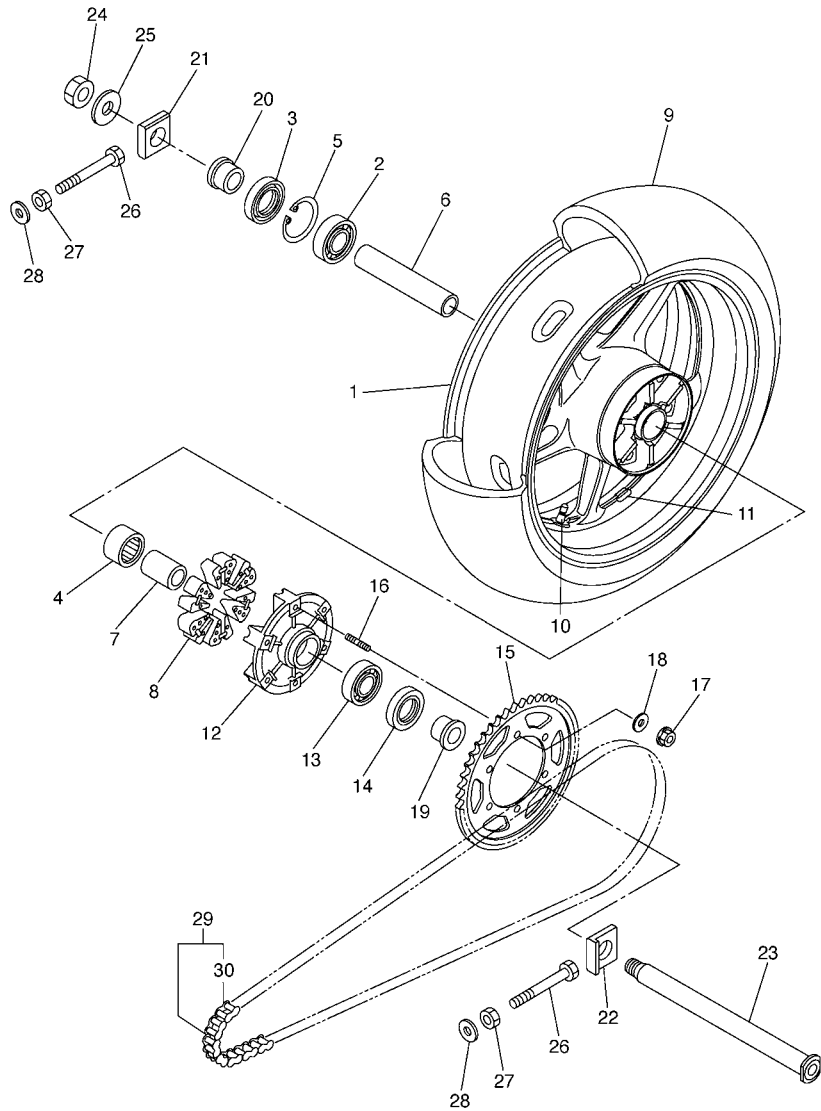

2D11300-E320

FIG. 32 REAR WHEEL

REF. NO.	PART NO.	DESCRIPTION	3C3A	3C3B	3C3C	REMARKS
1	5VY-25338-00-98	CAST WHEEL, REAR	1	1	1	LGB
2	93306-20531	BEARING	1	1	1	
3	93106-40013	OIL SEAL	1	1	1	
4	93317-33590	BEARING	1	1	1	
5	93420-61M07	CIRCLIP	1	1	1	
6	5PW-25317-00	SPACER, BEARING	1	1	1	
7	2D1-25377-00	COLLAR, WHEEL	1	1	1	
8	5VX-25364-00	DAMPER	6	6	6	
9	94119-17062	TIRE (190/50 ZR17M/C 73W D221)	1	1	1	UR DUNLOP
*		TIRE(190/50 ZR17M/C 73W PILOT)	1	1	1	UR LM MICHELIN
10	93900-00030	VALVE, RIM (TR412)	1	1	1	TAIHEIYO
11	5MT-25398-00	BALANCER, WHEEL (10G)	1	1	1	UN
	5MT-25398-10	BALANCER, WHEEL (20G)	1	1	1	UN
	5MT-25398-20	BALANCER, WHEEL (30G)	1	1	1	UN
12	2D1-25366-00	CLUTCH, HUB	1	1	1	
13	93306-20531	BEARING	1	1	1	
14	93106-40013	OIL SEAL	1	1	1	
15	2D1-25445-20	SPROCKET, DRIVEN (45T)	1	1	1	
16	90116-10485	BOLT, STUD	6	6	6	
17	90185-10009	NUT, SELF-LOCKING	6	6	6	
18	90201-10021	WASHER, PLATE	6	6	6	
19	90387-28001	COLLAR	1	1	1	
20	2D1-25383-00	COLLAR, WHEEL	1	1	1	
21	5VY-25388-00	PULLER, CHAIN 1	1	1	1	
22	5VY-25389-00	PULLER, CHAIN 2	1	1	1	
23	2D1-25381-00	AXLE, WHEEL	1	1	1	
24	90185-24007	NUT, SELF-LOCKING	1	1	1	

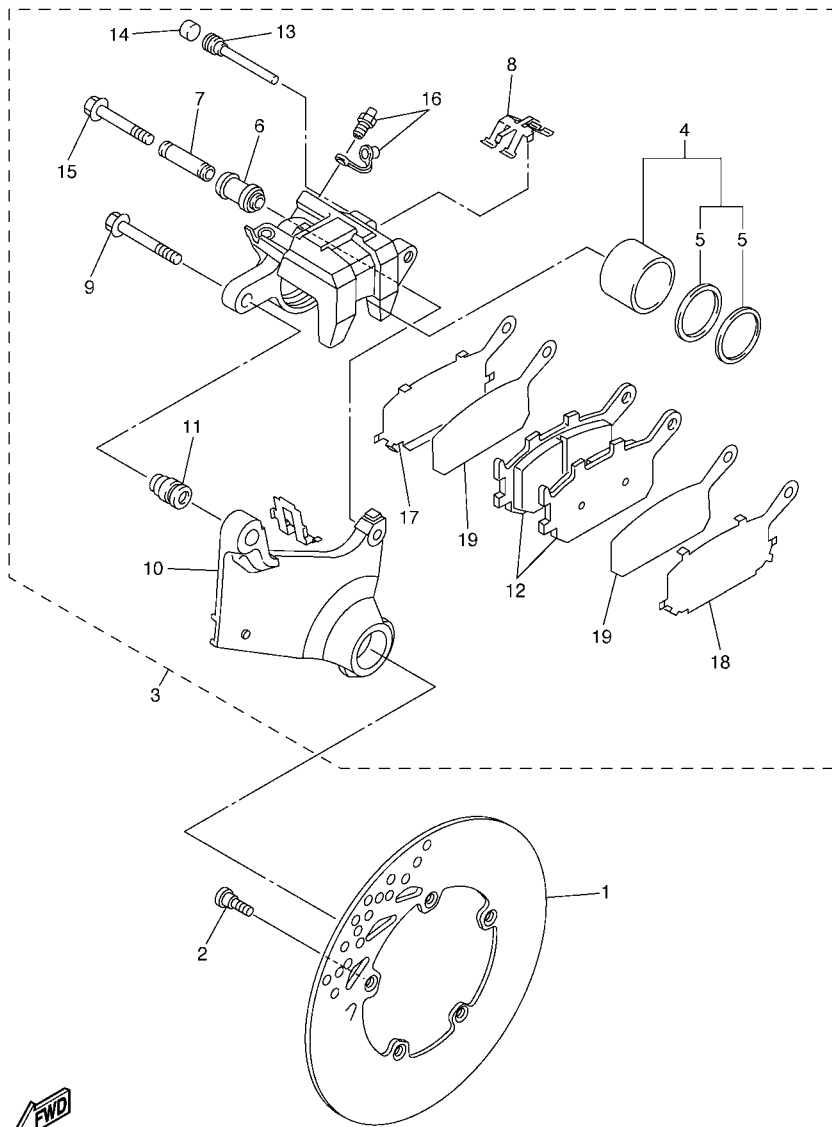
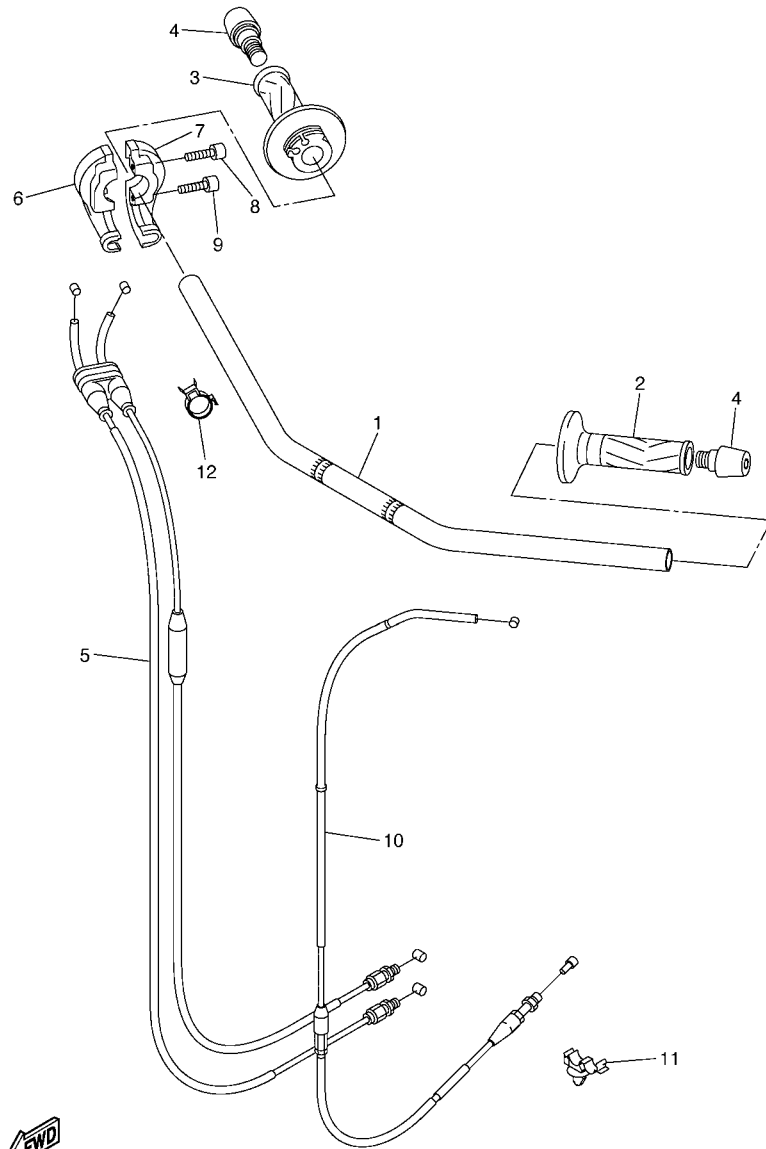

FIG. 33 REAR BRAKE CALIPER

REF. NO.	PART NO.	DESCRIPTION	3C3A	3C3B	3C3C	REMARKS
1	2D1-2582W-00	DISK, REAR BRAKE 2	1	1	1	
2	90149-08009	SCREW	5	5	5	
3	2D1-2580W-00	CALIPER ASSY, REAR 2	1	1	1	
4	5SL-W0057-00	.PISTON ASSY, CALIPER	1	1	1	
5	5SL-W0047-00	..CALIPER SEAL KIT	1	1	1	
6	5SL-25917-00	.BOOT, CALIPER	1	1	1	
7	5SL-25838-00	.SLEEVE, CALIPER	1	1	1	
8	5SL-25919-00	.SUPPORT, PAD	1	1	1	
9	5SL-25914-00	.PIN, SLIDE	1	1	1	
10	5VX-25921-50	.BRACKET, SUPPORT	1	1	1	
11	3JD-25917-00	.BOOT, CALIPER	1	1	1	
12	5VX-W0046-00	.BRAKE PAD KIT 2	1	1	1	
13	8CR-25924-00	.PIN, PAD	1	1	1	
14	5DH-25916-00	.PLUG	1	1	1	
15	5SL-25926-00	.BOLT	1	1	1	
16	1UY-W0048-00	.BLEED SCREW KIT	1	1	1	
17	5SL-25827-00	.SHIM, CALIPER	1	1	1	
18	5SL-25827-10	.SHIM, CALIPER	1	1	1	
19	5SL-25828-00	.SHIM, CALIPER	2	2	2	



2D11300-E330



3C3A300-F340

FIG. 34 STEERING HANDLE & CABLE

REF. NO.	PART NO.	DESCRIPTION	3C3A	3C3B	3C3C	REMARKS
1	2D1-26111-01	HANDLEBAR	1	1	1	
2	4YR-26241-02	GRIP (LEFT)	1	1	1	
3	4YR-26240-02	GRIP ASSY	1	1	1	
4	51J-26246-01	END, GRIP	2	2	2	
5	2D1-26302-00	THROTTLE CABLE ASSY	1	1	1	
6	3LN-26281-01	CAP, GRIP UPPER	1	1	1	
7	4BP-26282-00	CAP, GRIP LOWER	1	1	1	
8	91317-05020	BOLT	1	1	1	
9	91317-05025	BOLT	1	1	1	
10	3C3-26335-00	CABLE, CLUTCH	1	1	1	
11	90464-10008	CLAMP	1	1	1	
12	90464-20191	CLAMP	1	1	1	

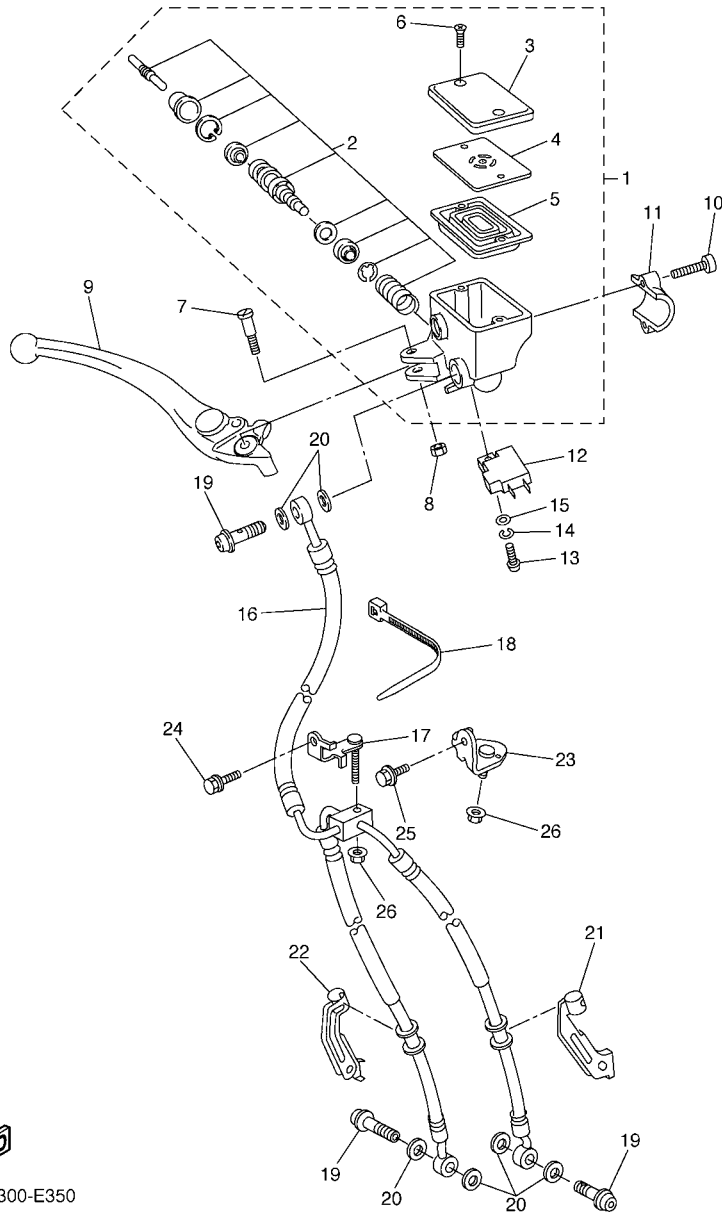

FWD
3C31300-E350

FIG. 35 FRONT MASTER CYLINDER

REF. NO.	PART NO.	DESCRIPTION	3C3A	3C3B	3C3C	REMARKS
1	3C3-W2587-00	MASTER CYLINDER SUB ASSY	1	1	1	
2	2D1-W0041-00	.CYLINDER KIT, MASTER	1	1	1	
3	5VS-25852-00	.CAP, RESERVOIR	1	1	1	
4	5VS-25855-00	.BUSH,DIAPHRAGM	1	1	1	
5	5VS-25854-00	.DIAPHRAGM, RESERVOIR	1	1	1	
6	5VS-2589H-00	.SCREW	2	2	2	
7	5VS-2589F-00	BOLT, LEVER	1	1	1	
8	95617-06100	NUT, U	1	1	1	
9	5VS-83922-00	LEVER 2	1	1	1	
10	5VS-26332-00	BOLT	2	2	2	
11	5VS-25867-00	BRACKET, MASTER CYLINDER	1	1	1	
12	4HM-83980-00	FRONT STOP SWITCH ASSY	1	1	1	
13	98502-04012	SCREW, PAN HEAD	1	1	1	
14	92902-04100	WASHER, SPRING	1	1	1	
15	92902-04600	WASHER, PLATE	1	1	1	
16	3C3-25872-00	HOSE, BRAKE 1	1	1	1	
17	2D1-23857-00	HOLDER	1	1	1	
18	3MA-82591-00	BAND	1	1	1	
19	90401-10172	BOLT, UNION	3	3	3	
20	90430-10005	GASKET	6	6	6	
21	2D1-25875-00	HOLDER, BRAKE HOSE 1	1	1	1	
22	2D1-25876-00	HOLDER, BRAKE HOSE 2	1	1	1	
23	3C3-23378-00	BRACKET, HORN	1	1	1	
24	95817-06012	BOLT, FLANGE	1	1	1	
25	90105-06556	BOLT, FLANGE	1	1	1	
26	95707-06500	NUT, FLANGE	2	2	2	

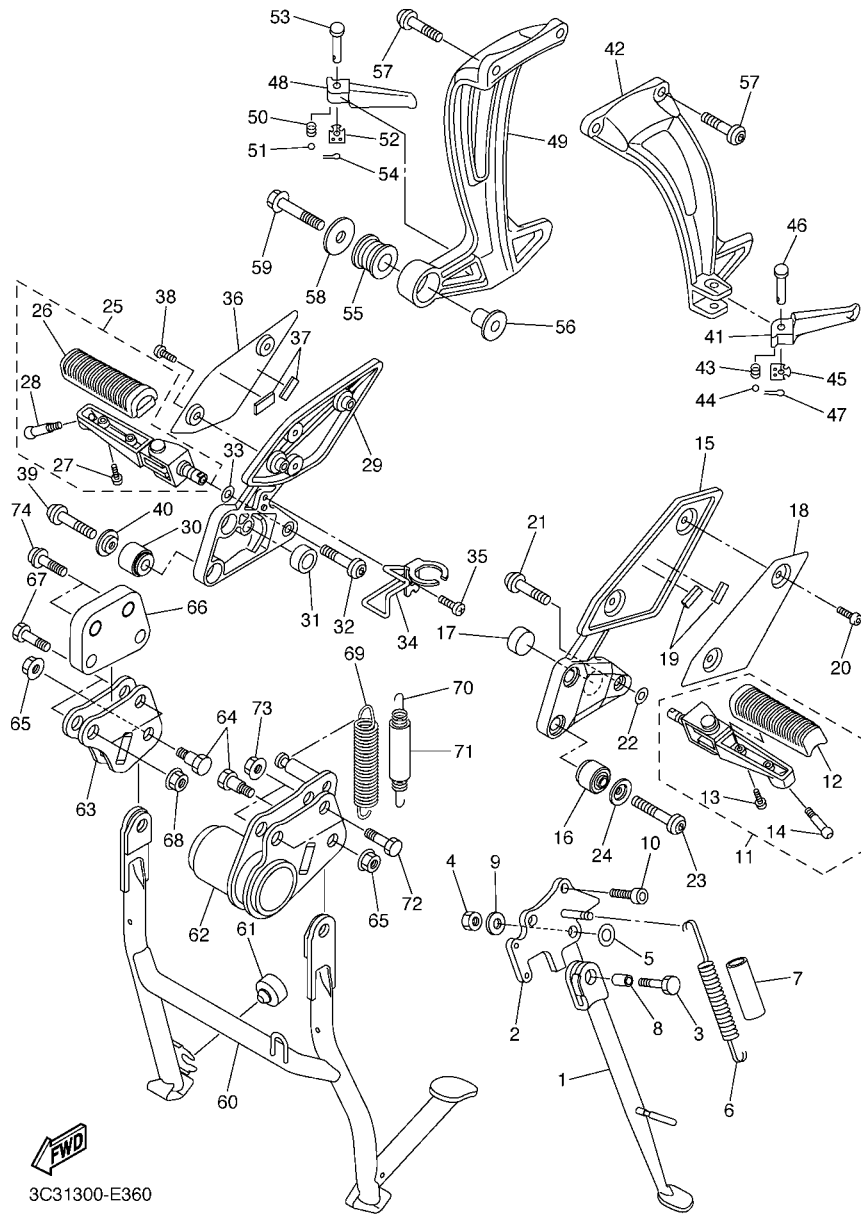

3C31300-E360

FIG. 36 STAND & FOOTREST

REF. NO.	PART NO.	DESCRIPTION	3C3A	3C3B	3C3C	REMARKS
1	2D1-27311-00	STAND, SIDE	1	1	1	
2	2D1-27321-00	BRACKET, SIDE STAND	1	1	1	
3	90101-10006	BOLT	1	1	1	
4	90185-10037	NUT, SELF-LOCKING	1	1	1	
5	90201-16020	WASHER, PLATE	1	1	1	
6	90506-18008	SPRING, TENSION	1	1	1	
7	90445-19002	HOSE (L60)	1	1	1	
8	90387-10050	COLLAR	1	1	1	
9	90201-101J1	WASHER, PLATE	1	1	1	
10	90110-10010	BOLT, HEXAGON SOCKET HEAD	2	2	2	
11	2D1-27410-00	FRONT FOOTREST ASSY (LEFT)	1	1	1	
12	4BP-27413-00	.COVER, FOOTREST	1	1	1	
13	90157-05025	.SCREW, PAN HEAD	2	2	2	
14	90109-08174	.BOLT	1	1	1	
15	2D1-27442-00	BRACKET 2	1	1	1	
16	1NL-27424-00	DAMPER, FOOTREST 2	2	2	2	
17	5VX-27114-00	STOPPER, MAIN STAND	1	1	1	
18	2D1-27486-00	COVER 1	1	1	1	
19	1HX-27415-00	PLATE, DAMPER	2	2	2	
20	90111-05015	BOLT,HEX. SOCKET BUTTON	2	2	2	
21	90109-103A9	BOLT	1	1	1	
22	90206-17084	WASHER, WAVE	1	1	1	
23	90110-08071	BOLT, HEXAGON SOCKET HEAD	2	2	2	
24	90209-08295	WASHER	2	2	2	
25	2D1-27420-00	FRONT FOOTREST ASSY (RIGHT)	1	1	1	
26	4BP-27413-00	.COVER, FOOTREST	1	1	1	
27	90157-05025	.SCREW, PAN HEAD	2	2	2	

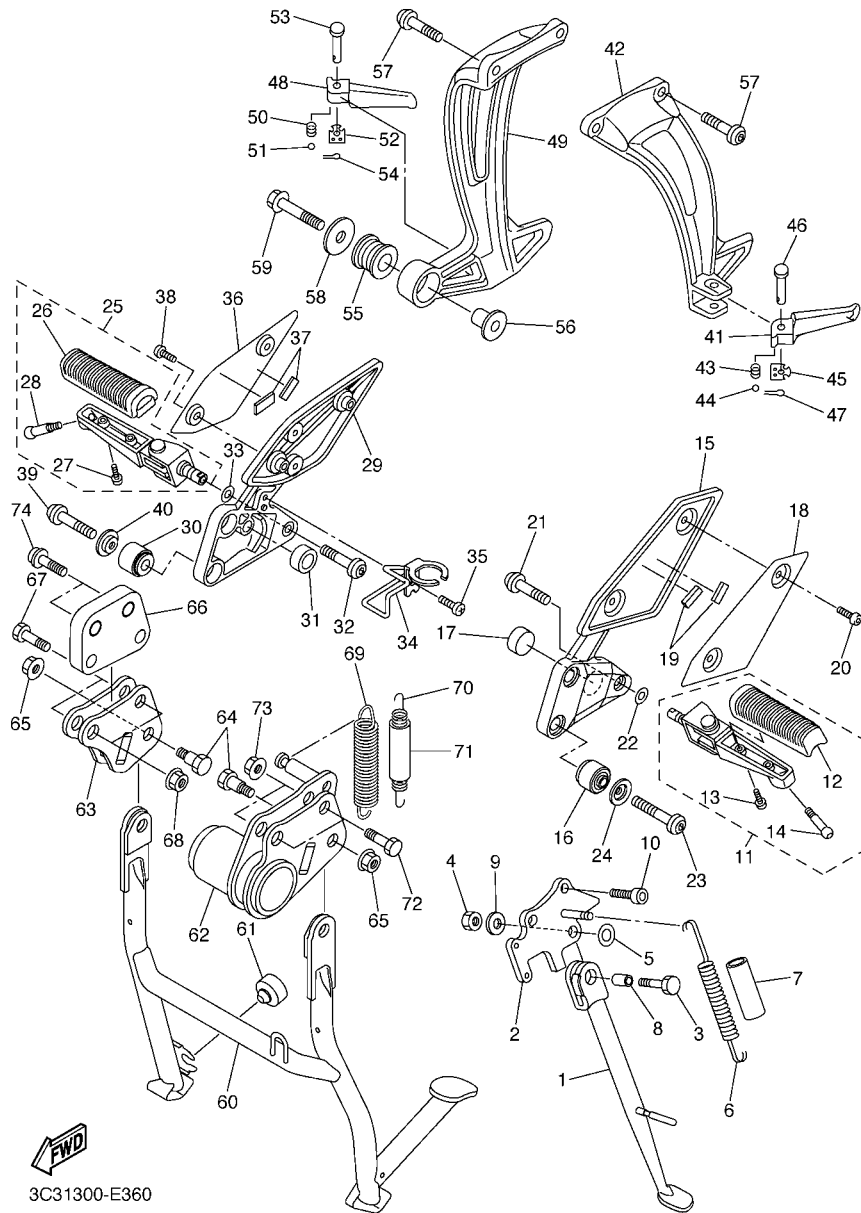

3C31300-E360

FIG. 36 STAND & FOOTREST

REF. NO.	PART NO.	DESCRIPTION	3C3A	3C3B	3C3C	REMARKS
28	90109-08174	.BOLT	1	1	1	
29	2D1-27443-00	BRACKET 3	1	1	1	
30	1NL-27424-00	DAMPER, FOOTREST 2	2	2	2	
31	5VX-27114-00	STOPPER, MAIN STAND	1	1	1	
32	90109-103A9	BOLT	1	1	1	
33	90206-17084	WASHER, WAVE	1	1	1	
34	2D1-2144G-00	STAY, STOP SWITCH	1	1	1	
35	98507-06008	SCREW, PAN HEAD	1	1	1	
36	2D1-27487-00	COVER 2	1	1	1	
37	1HX-27415-00	PLATE, DAMPER	2	2	2	
38	90111-05015	BOLT,HEX. SOCKET BUTTON	2	2	2	
39	90110-08071	BOLT, HEXAGON SOCKET HEAD	2	2	2	
40	90209-08295	WASHER	2	2	2	
41	3VR-27431-01	FOOTREST, REAR 1	1	1	1	
42	2D1-2741L-00	BRACKET 4	1	1	1	
43	90501-12743	SPRING, COMPRESSION	1	1	1	
44	93501-04011	BALL	1	1	1	
45	5VX-27437-00	WASHER, SPECIAL	1	1	1	
46	91702-08040	PIN, CLEVIS	1	1	1	
47	91401-25015	PIN, COTTER	1	1	1	
48	3VR-27441-01	FOOTREST, REAR 2	1	1	1	
49	2D1-2742L-00	BRACKET 5	1	1	1	
50	90501-12743	SPRING, COMPRESSION	1	1	1	
51	93501-04011	BALL	1	1	1	
52	5VX-27437-00	WASHER, SPECIAL	1	1	1	
53	91702-08040	PIN, CLEVIS	1	1	1	
54	91401-25015	PIN, COTTER	1	1	1	

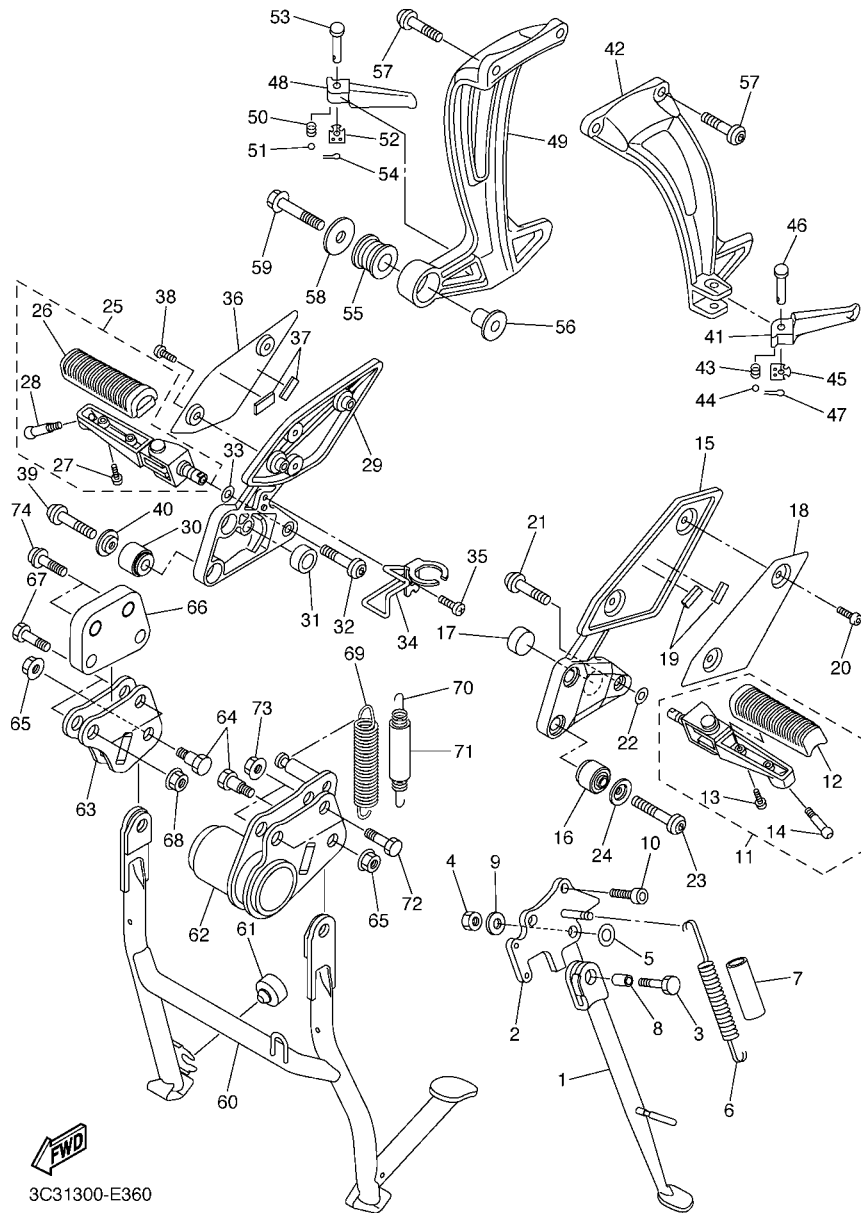

3C31300-E360

FIG. 36 STAND & FOOTREST

REF. NO.	PART NO.	DESCRIPTION	3C3A	3C3B	3C3C	REMARKS
55	36Y-27424-01	DAMPER, FOOTREST 2	1	1	1	
56	90387-10636	COLLAR	1	1	1	
57	90109-085G6	BOLT	4	4	4	
58	90201-10669	WASHER, PLATE	1	1	1	
59	95814-10040	BOLT, FLANGE	1	1	1	
60	3C3-27111-00	STAND, MAIN	1	1	1	
61	371-27114-00	STOPPER, MAIN STAND	1	1	1	
62	3C3-27151-01	BRACKET, MAIN STAND	1	1	1	
63	3C3-27152-00	BRACKET, MAIN STAND 2	1	1	1	
64	90109-101E6	BOLT	2	2	2	
65	95607-10200	NUT, U FLANGE	2	2	2	
66	3C3-274A3-00	BEACKET, ADAPTER 1	1	1	1	
67	90101-10004	BOLT	2	2	2	
68	95607-10200	NUT, U FLANGE	2	2	2	
69	90506-40007	SPRING, TENSION	1	1	1	
70	90506-23010	SPRING, TENSION	1	1	1	
71	90445-19003	HOSE	1	1	1	
72	90101-10004	BOLT	2	2	2	
73	95607-10200	NUT, U FLANGE	2	2	2	
74	90109-105G7	BOLT	2	2	2	

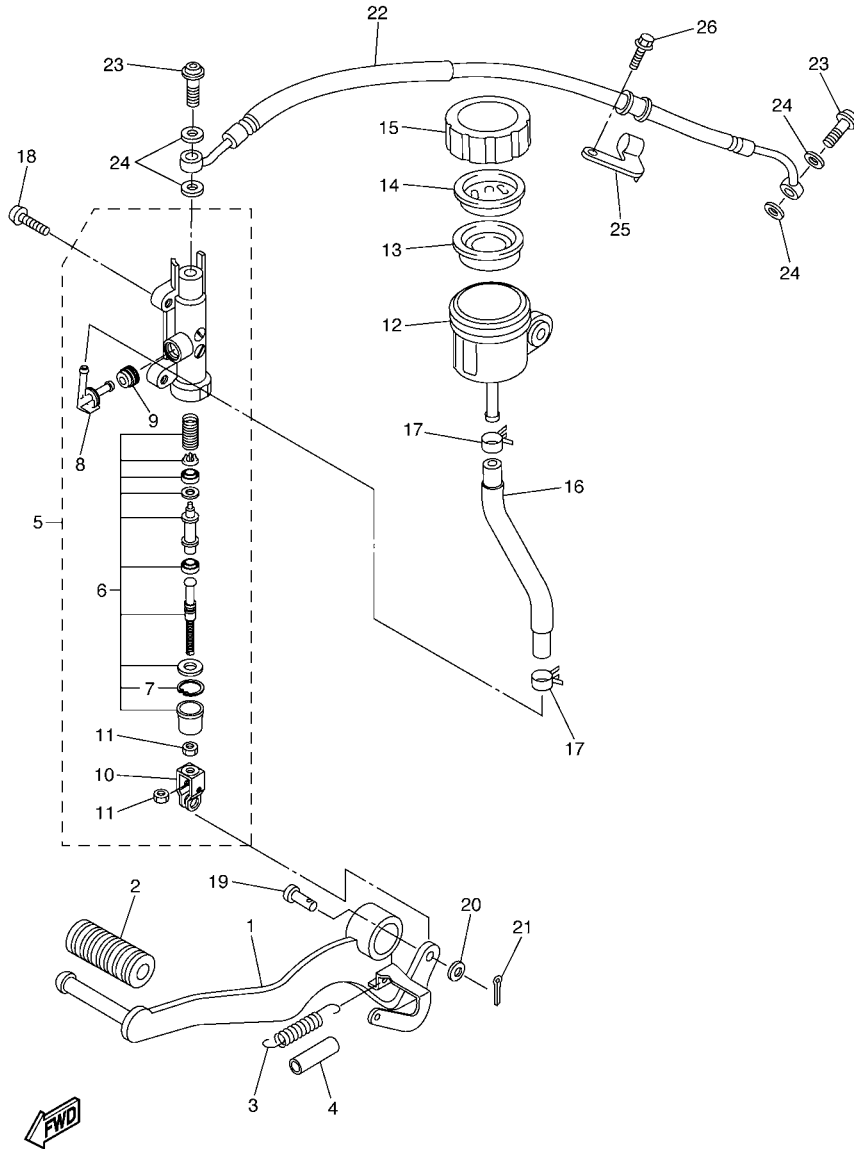

2D11300-E370

FIG. 37 REAR MASTER CYLINDER

REF. NO.	PART NO.	DESCRIPTION	3C3A	3C3B	3C3C	REMARKS
1	2D1-27211-00	PEDAL, BRAKE	1	1	1	
2	5EB-18113-00	COVER, SHIFT PEDAL	1	1	1	
3	90506-20014	SPRING, TENSION	1	1	1	
4	90446-15386	HOSE	1	1	1	
5	2D1-2583V-00	RR. MASTER CYLINDER ASSY.	1	1	1	
6	5VX-W0042-50	.CYLINDER KIT, MASTER	1	1	1	
7	3LN-2585G-00	.CIRCLIP	1	1	1	
8	2D1-2582A-00	.JOINT	1	1	1	
9	4BP-2585F-00	.BUSH	1	1	1	
10	4BP-27222-01	.JOINT	1	1	1	
11	90170-08010	.NUT	2	2	2	
12	2D1-25894-00	TANK, RESERVOIR	1	1	1	
13	5SL-25854-00	DIAPHRAGM, RESERVOIR	1	1	1	
14	5SL-25855-00	BUSH,DIAPHRAGM	1	1	1	
15	5SL-25852-00	CAP, RESERVOIR	1	1	1	
16	2D1-25895-00	HOSE, RESERVOIR	1	1	1	
17	90467-120A3	CLIP	2	2	2	
18	92014-08020	BOLT, BUTTON HEAD	2	2	2	
19	90240-08124	PIN, CLEVIS	1	1	1	
20	90201-08083	WASHER, PLATE	1	1	1	
21	91401-20012	PIN, COTTER	1	1	1	
22	2D1-25874-00	HOSE, BRAKE	1	1	1	
23	90401-10172	BOLT, UNION	2	2	2	
24	90430-10005	GASKET	4	4	4	
25	2D1-25886-00	HOLDER, BRAKE HOSE	1	1	1	
26	90119-05020	BOLT, WITH WASHER	1	1	1	

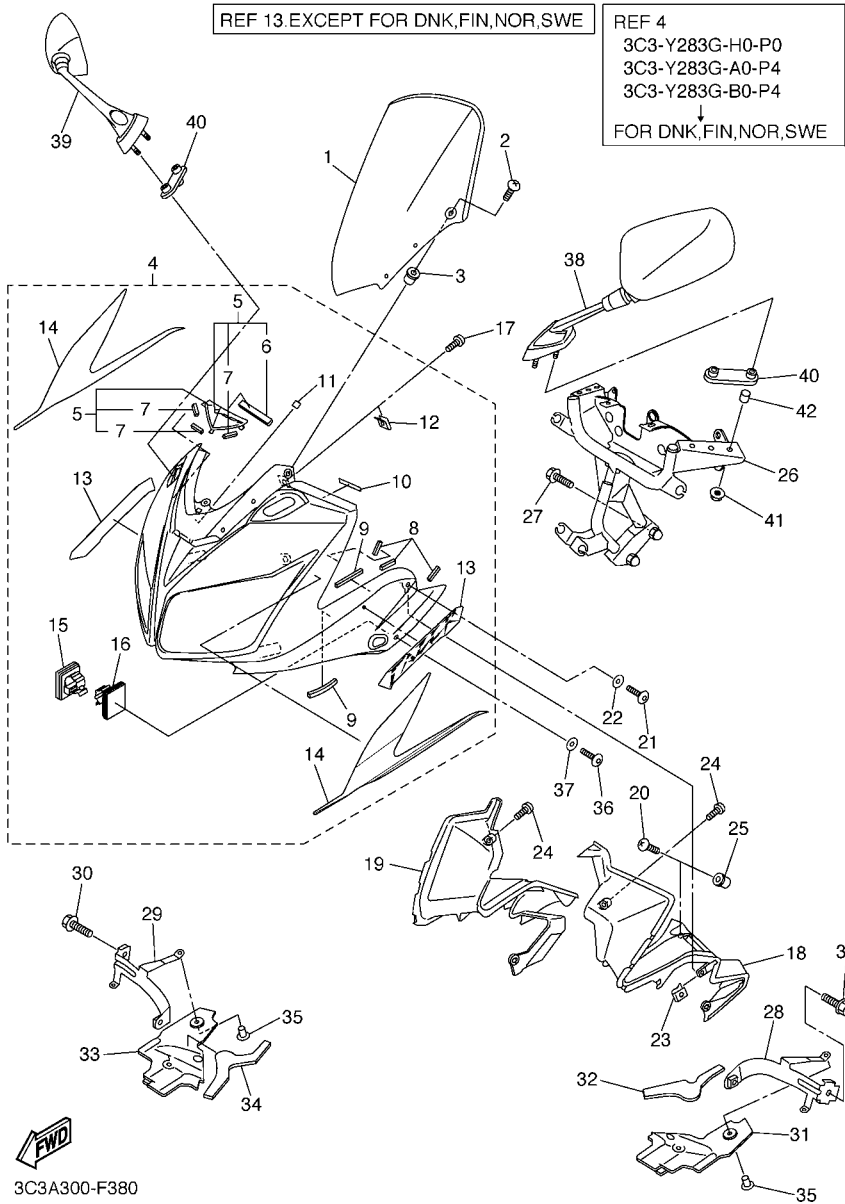

3C3A300-F380

FIG. 38 COWLING 1

REF. NO.	PART NO.	DESCRIPTION	3C3A	3C3B	3C3C	REMARKS
1	3C3-28381-00	WINDSHIELD	1	1		
	3C3-28381-10	WINDSHIELD			1	
2	90150-05024	SCREW, ROUND HEAD	6	6	6	
3	90179-05523	NUT	6	6	6	
4	3C3-Y283G-G0-P0	BODY, FRONT UPPER 1	1	1	1	UR FOR DPBMU
	3C3-Y283G-80-P4	BODY, FRONT UPPER 1	1	1	1	UR SMX FOR BNM5
	3C3-Y283G-90-P4	BODY, FRONT UPPER 1	1	1	1	UR SMX FOR DRMK
	3C3-Y283G-H0-P0	BODY, FRONT UPPER 1	1			UR FOR DPBMU
	3C3-Y283G-A0-P4	BODY, FRONT UPPER 1	1			UR SMX FOR BNM5
	3C3-Y283G-B0-P4	BODY, FRONT UPPER 1	1			UR SMX FOR DRMK
5	3C3-Y283W-10	.COVER ASSY	1	1	1	
6	3C3-28371-01	..DAMPER	1	1	1	
7	3C3-28372-00	..DAMPER	3	3	3	
8	3C3-2837J-00	.DAMPER 5	6	6	6	
9	4XV-2834E-00	.DAMPER 3	4	4	4	
10	3P6-28307-00	.SEAL	2	2	2	
11	5JW-23844-00	.SEAL	1	1	1	
12	90183-05076	.NUT, SPRING	2	2	2	
13	3C3-28315-00	.EMBLEM	2	2	2	UR FOR DPBMU
	3C3-28315-30	.EMBLEM	2	2	2	UR FOR BNM5,DRMK
14	3C3-283B1-00	.GRAPHIC SET	1	1	1	UR FOR BNM5
	3C3-283B1-10	.GRAPHIC SET	1	1	1	UR FOR DRMK
15	90464-62085	.CLAMP	1	1	1	
16	90464-20003	.CLAMP	1	1	1	
17	90154-05007	SCREW, BINDING	2	2	2	
18	3C3-2836K-00	PANEL, INNER 1	1	1	1	
19	3C3-2836L-00	PANEL, INNER 2	1	1	1	

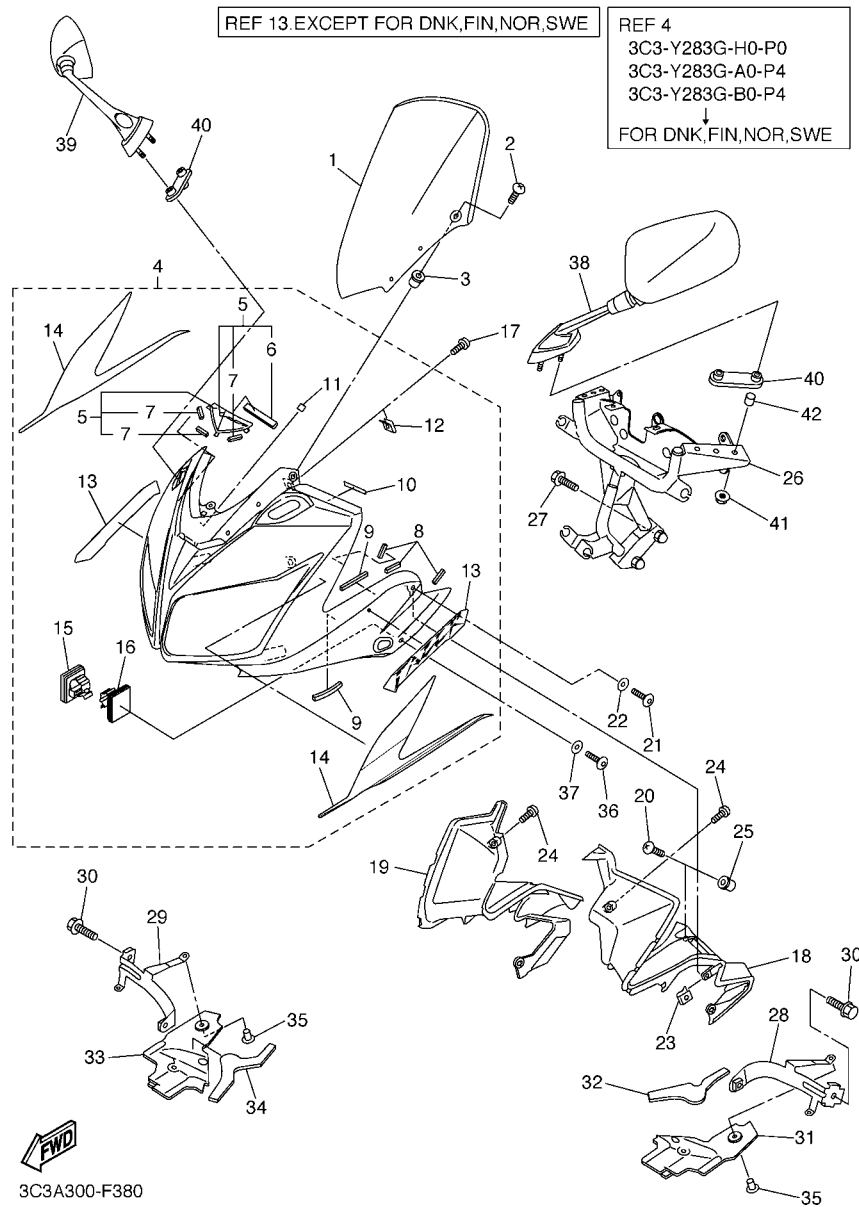
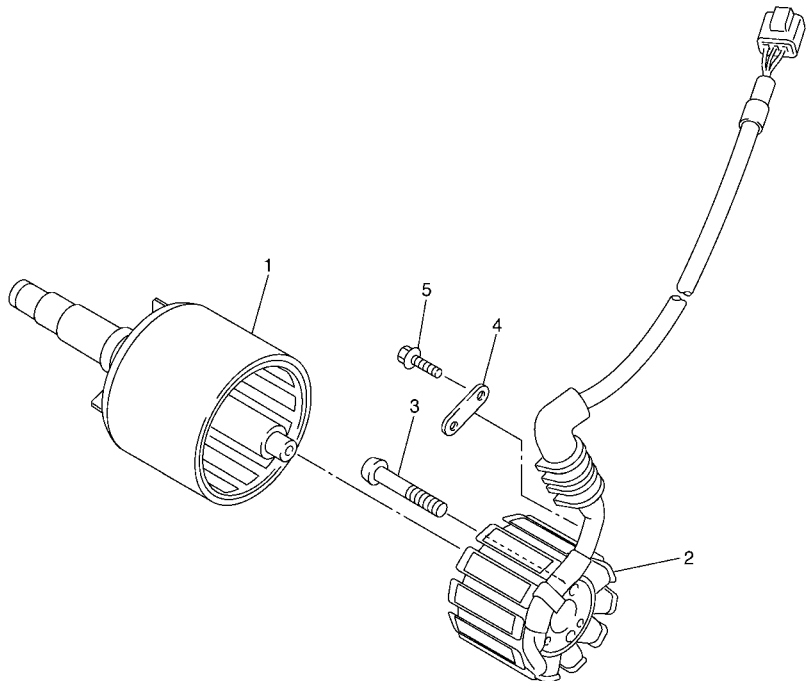

FIG. 38 COWLING 1

REF. NO.	PART NO.	DESCRIPTION	3C3A	3C3B	3C3C	REMARKS
20	90154-05007	SCREW, BINDING	2	2	2	
21	90110-06200	BOLT, HEXAGON SOCKET HEAD	2	2	2	
22	90202-06170	WASHER, PLATE	2	2	2	
23	90183-06053	NUT, SPRING	2	2	2	
24	90154-05007	SCREW, BINDING	2	2	2	
25	90179-05523	NUT	2	2	2	
26	3C3-28356-00	STAY 1	1	1	1	
27	95827-08035	BOLT, FLANGE	2	2	2	
28	3C3-2836A-00	BRACKET 1	1	1	1	
29	3C3-2836E-00	BRACKET 2	1	1	1	
30	95807-06010	BOLT, FLANGE	2	2	2	
31	3C3-2835U-00	PANEL 1	1	1	1	
32	3C3-2834E-00	DAMPER 3	1	1	1	
33	3C3-2835V-00	PANEL 2	1	1	1	
34	3C3-2834F-00	DAMPER	1	1	1	
35	90269-06008	RIVET	4	4	4	
36	90110-06200	BOLT, HEXAGON SOCKET HEAD	2	2	2	
37	90202-06170	WASHER, PLATE	2	2	2	
38	3C3-26280-00	REAR VIEW MIRROR ASSY (LEFT)	1	1	1	
39	3C3-26290-00	REAR VIEW MIRROR ASSY (RIGHT)	1	1	1	
40	3C3-26298-00	PLATE, MIRROR FITTING 1	2	2	2	
41	95707-06500	NUT, FLANGE	4	4	4	
42	90387-064T3	COLLAR	4	4	4	

FIG. 39 GENERATOR



REF. NO.	PART NO.	DESCRIPTION	3C3A	3C3B	3C3C	REMARKS
1	5VY-81450-00	ROTOR ASSY	1	1	1	
2	2D1-81410-01	STATOR ASSY	1	1	1	
3	90149-06067	SCREW	3	3	3	
4	4C8-15191-00	PLATE	1	1	1	
5	90105-06078	BOLT, FLANGE	1	1	1	

 5VY1300-C400

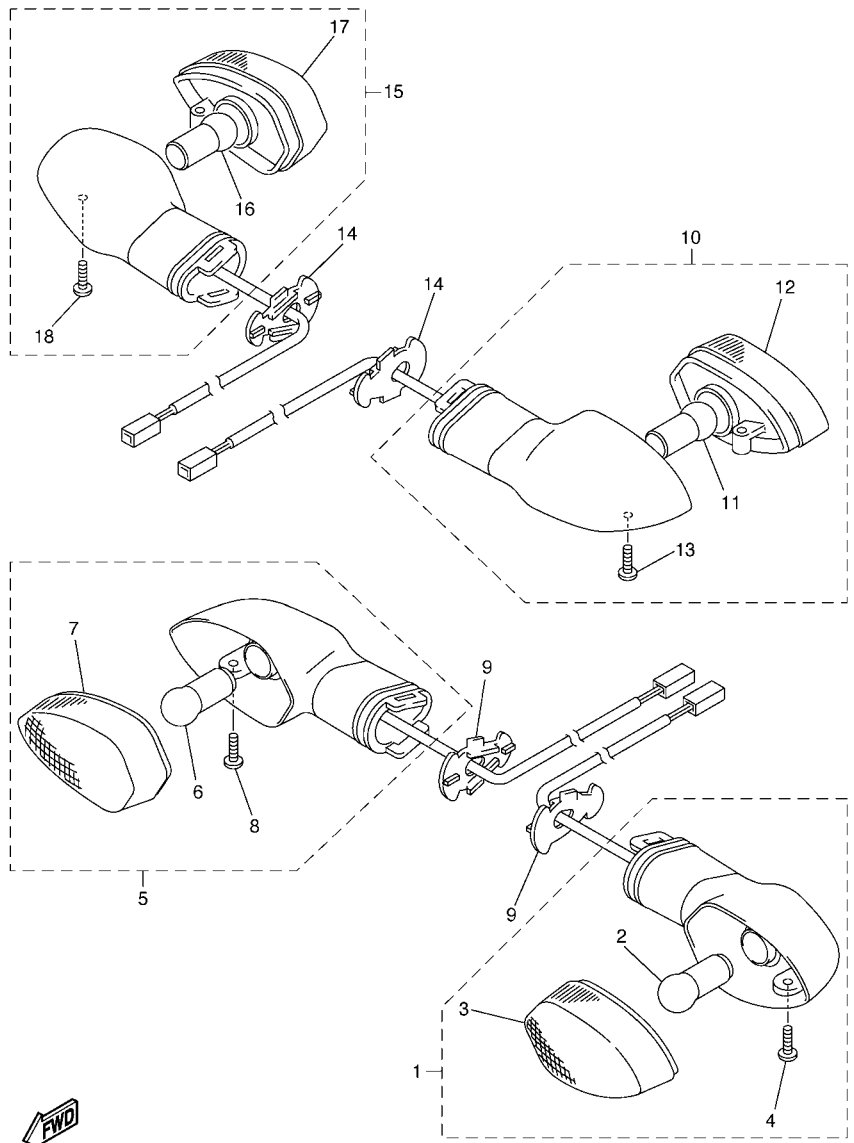

FWD
2D11300-E400

FIG. 41 FLASHER LIGHT

REF. NO.	PART NO.	DESCRIPTION	3C3A	3C3B	3C3C	REMARKS
1	5PW-83310-01	FRONT FLASHER LIGHT ASSY 1	1	1	1	
2	1KH-83311-00	.BULB (12V-10W)	1	1	1	
3	5PW-8333A-00	.LENS COMP	1	1	1	
4	97706-04012	.SCREW, TAPPING	1	1	1	
5	5PW-83320-01	FRONT FLASHER LIGHT ASSY 2	1	1	1	
6	1KH-83311-00	.BULB (12V-10W)	1	1	1	
7	5PW-8334A-00	.LENS COMP	1	1	1	
8	97706-04012	.SCREW, TAPPING	1	1	1	
9	2D1-83318-00	STAY, FLASHER 1	2	2	2	
10	2D1-83330-20	REAR FLASHER LIGHT ASSY 1	1	1	1	
11	1KH-83311-00	.BULB (12V-10W)	1	1	1	
12	5PW-8334A-00	.LENS COMP	1	1	1	
13	97706-04012	.SCREW, TAPPING	1	1	1	
14	2D1-83318-00	STAY, FLASHER 1	2	2	2	
15	2D1-83340-20	REAR FLASHER LIGHT ASSY 2	1	1	1	
16	1KH-83311-00	.BULB (12V-10W)	1	1	1	
17	5PW-8333A-00	.LENS COMP	1	1	1	
18	97706-04012	.SCREW, TAPPING	1	1	1	

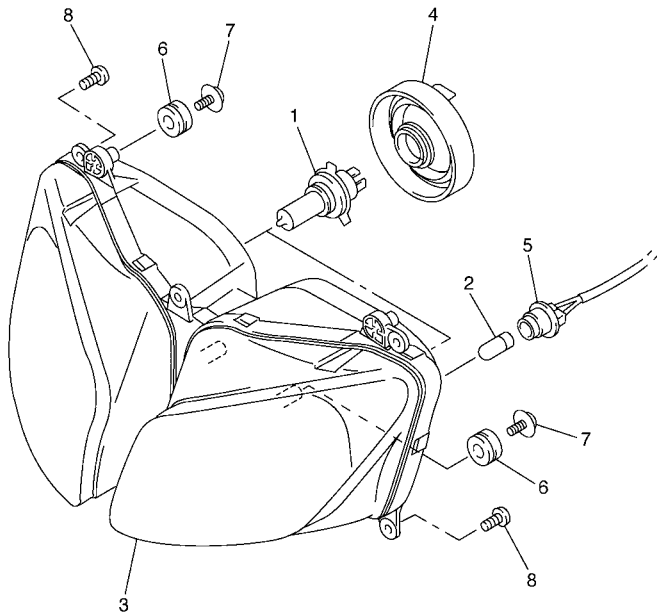
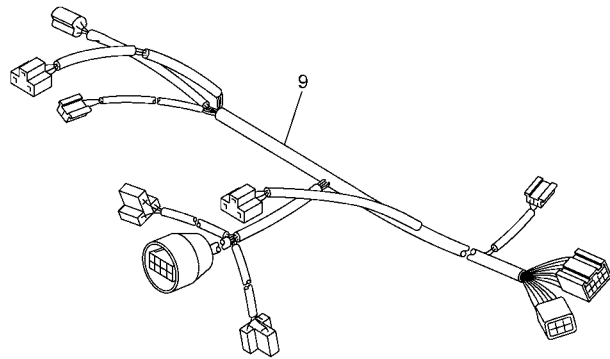

3C31300-E430

FIG. 43 HEADLIGHT

REF. NO.	PART NO.	DESCRIPTION	3C3A	3C3B	3C3C	REMARKS
1	8V0-84314-00	BULB (12V-60/55W)	2	2	2	
2	4SV-84347-00	BULB (12V-5W)	2	2	2	
3	3C3-84310-00	HEADLIGHT UNIT ASSY	1	1		
	3C3-84310-10	HEADLIGHT UNIT ASSY	1		1	FOR GBR,IRL,ZAF
4	5LV-84397-00	COVER, SOCKET	2	2	2	
5	3C3-84312-00	CORD ASSY	2	2	2	
6	90480-14229	GROMMET	4	4	4	
7	90164-05014	SCREW, TAPPING	4	4	4	
8	97707-50016	SCREW, TRUSS HEAD TAPPING	5	5	5	
9	3C3-84359-00	CORD, HEADLIGHT	1	1	1	

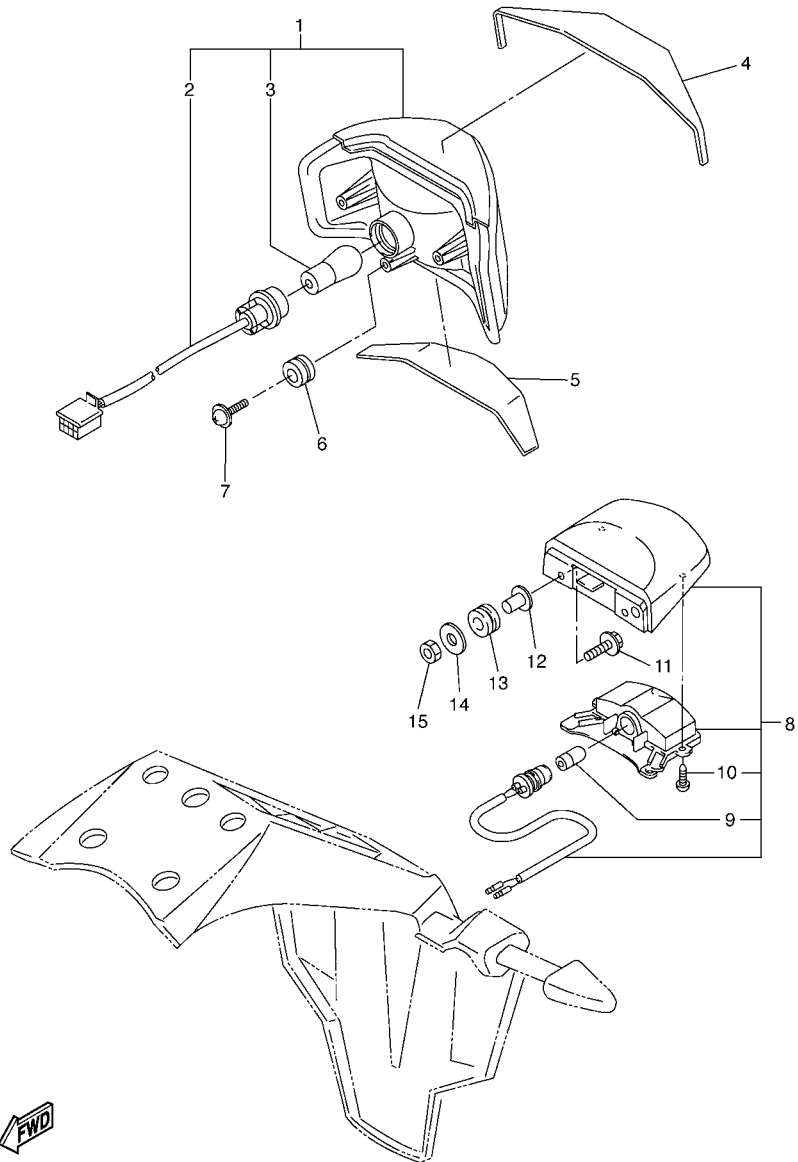
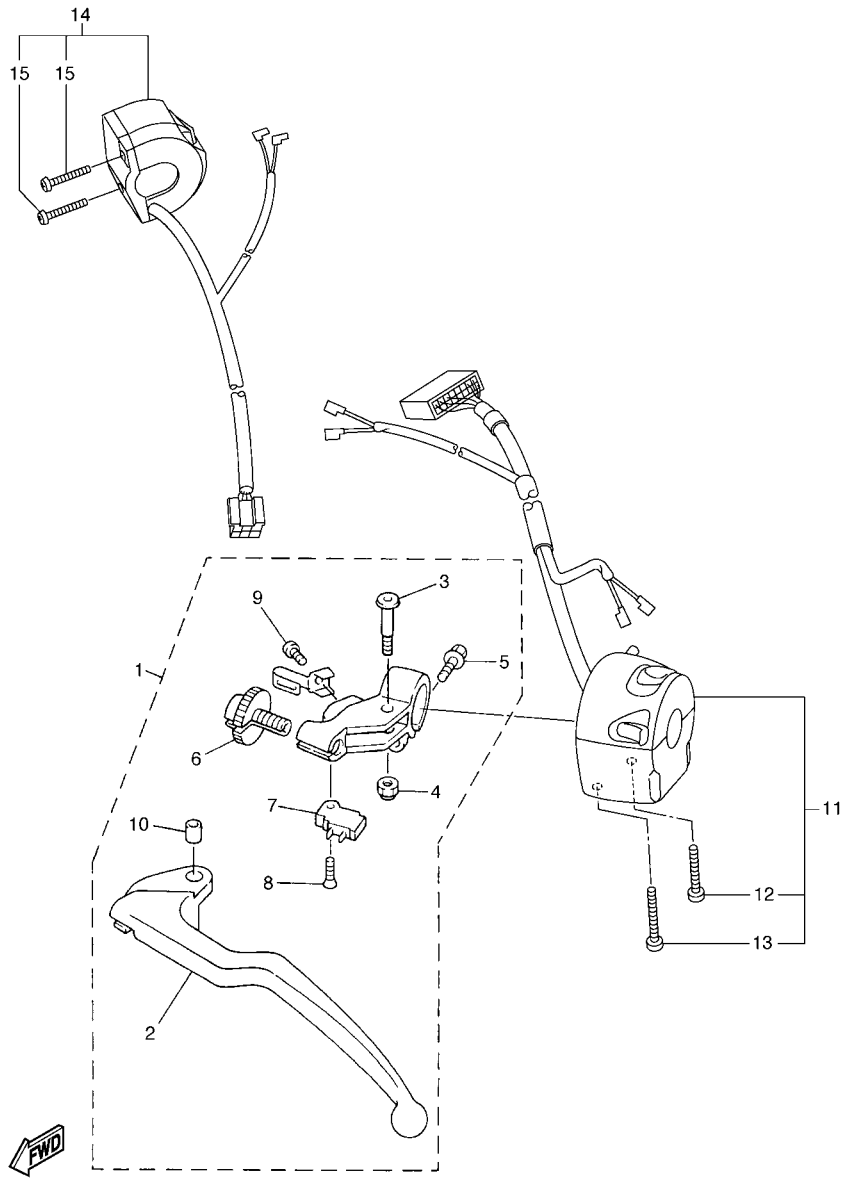

FIG. 44 TAILLIGHT

REF. NO.	PART NO.	DESCRIPTION	3C3A	3C3B	3C3C	REMARKS
1	2D1-84710-00	TAILLIGHT UNIT ASSY	1	1	1	
2	2D1-84735-00	.CORD ASSY	1	1	1	
3	1A2-84714-41	.BULB (12V-21/5W)	1	1	1	
4	3C3-84736-00	DAMPER, TAIL 1	1	1	1	
5	2D1-84737-00	DAMPER, TAIL 2	1	1	1	
6	90480-18276	GROMMET	3	3	3	
7	90164-05014	SCREW, TAPPING	3	3	3	
8	2D1-84745-00	LICENCE LIGHT UNIT ASSY	1	1	1	
9	4HC-84744-00	.BULB (12V-5W)	1	1	1	
10	97706-04012	.SCREW, TAPPING	2	2	2	
11	90159-05011	SCREW, WITH WASHER	2	2	2	
12	90387-05031	COLLAR	2	2	2	
13	90480-11009	GROMMET	2	2	2	
14	92907-05200	WASHER	2	2	2	
15	95602-05100	NUT, U	2	2	2	



2D11300-E430



3C31300-E450

FIG. 45 HANDLE SWITCH & LEVER

REF. NO.	PART NO.	DESCRIPTION	3C3A	3C3B	3C3C	REMARKS
1	4XV-82910-15	LEVER HOLDER ASSY (LEFT)	1	1	1	
2	4XV-83912-11	.LEVER 1	1	1	1	
3	2C0-83945-00	.BOLT, LEVER	1	1	1	
4	95607-06200	.NUT, SELF U-FLANGE	1	1	1	
5	95027-06020	.BOLT, FLANGE	1	1	1	
6	5LV-83951-00	.BOLT, CABLE ADJUSTING	1	1	1	
7	4XV-82917-01	.SWITCH	1	1	1	
8	98707-03016	.SCREW, FLAT HEAD	1	1	1	
9	98507-04010	.SCREW, PAN HEAD	1	1	1	
10	5JJ-83913-00	.COLLAR, LEVER 1	1	1	1	
11	3C3-83969-00	SWITCH, HANDLE 5	1	1	1	
12	98507-05030	.SCREW, PAN HEAD	1	1	1	
13	98507-05045	.SCREW, PAN HEAD	1	1	1	
14	2D1-83975-00	SWITCH, HANDLE 2	1	1	1	
15	98507-05022	.SCREW, PAN HEAD	2	2	2	

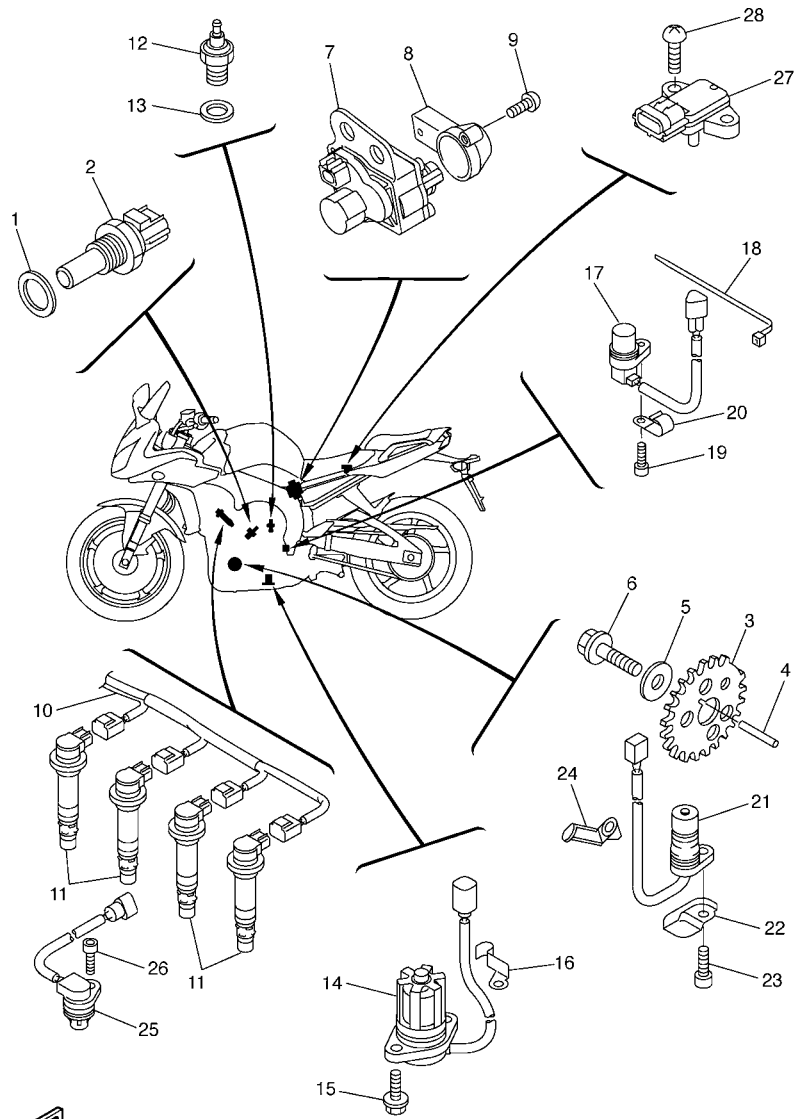

3C31300-E460

FIG. 46 ELECTRICAL 1

REF. NO.	PART NO.	DESCRIPTION	3C3A	3C3B	3C3C	REMARKS
1	90201-12790	WASHER, PLATE	1	1	1	
2	8CC-85790-01	THERMOSENSOR ASSY	1	1	1	
3	2D1-81673-00	ROTOR	1	1	1	
4	90282-03001	KEY, STRAIGHT	1	1	1	
5	90201-10039	WASHER, PLATE	1	1	1	
6	90105-10290	BOLT, FLANGE	1	1	1	
7	2D1-85820-00	SERVO MOTOR ASSY	1	1	1	
8	5VY-85829-00	COVER, SERVO MOTOR	1	1	1	
9	97702-50514	SCREW, TAPPING	2	2	2	
10	2D1-82309-00	WIRE, SUB LEAD	1	1	1	
11	5VY-82310-00	IGNITION COIL ASSY	4	4	4	
12	3GB-82540-01	NEUTRAL SWITCH ASSY	1	1	1	
13	90430-10148	GASKET	1	1	1	
14	5VY-85720-00	OIL LEVEL GAUGE ASSY	1	1	1	
15	95022-06016	BOLT, FLANGE	2	2	2	
16	90465-08053	CLAMP	1	1	1	
17	4XV-83755-02	SENSOR, SPEED	1	1	1	
18	90464-51001	CLAMP	1	1	1	
19	90110-06161	BOLT, HEXAGON SOCKET HEAD	1	1	1	
20	90462-08057	CLAMP	1	1	1	
21	5VY-81670-01	PICK-UP ASSY	1	1	1	
22	5VY-15589-00	PLATE, CLUTCH COVER	1	1	1	
23	90110-06161	BOLT, HEXAGON SOCKET HEAD	1	1	1	
24	90465-08054	CLAMP	1	1	1	
25	5VY-85896-00	SENSOR, CAM POSITION	1	1	1	
26	90110-06175	BOLT, HEXAGON SOCKET HEAD	1	1	1	
27	2C0-82380-00	SENSOR, PRESSURE	1	1	1	

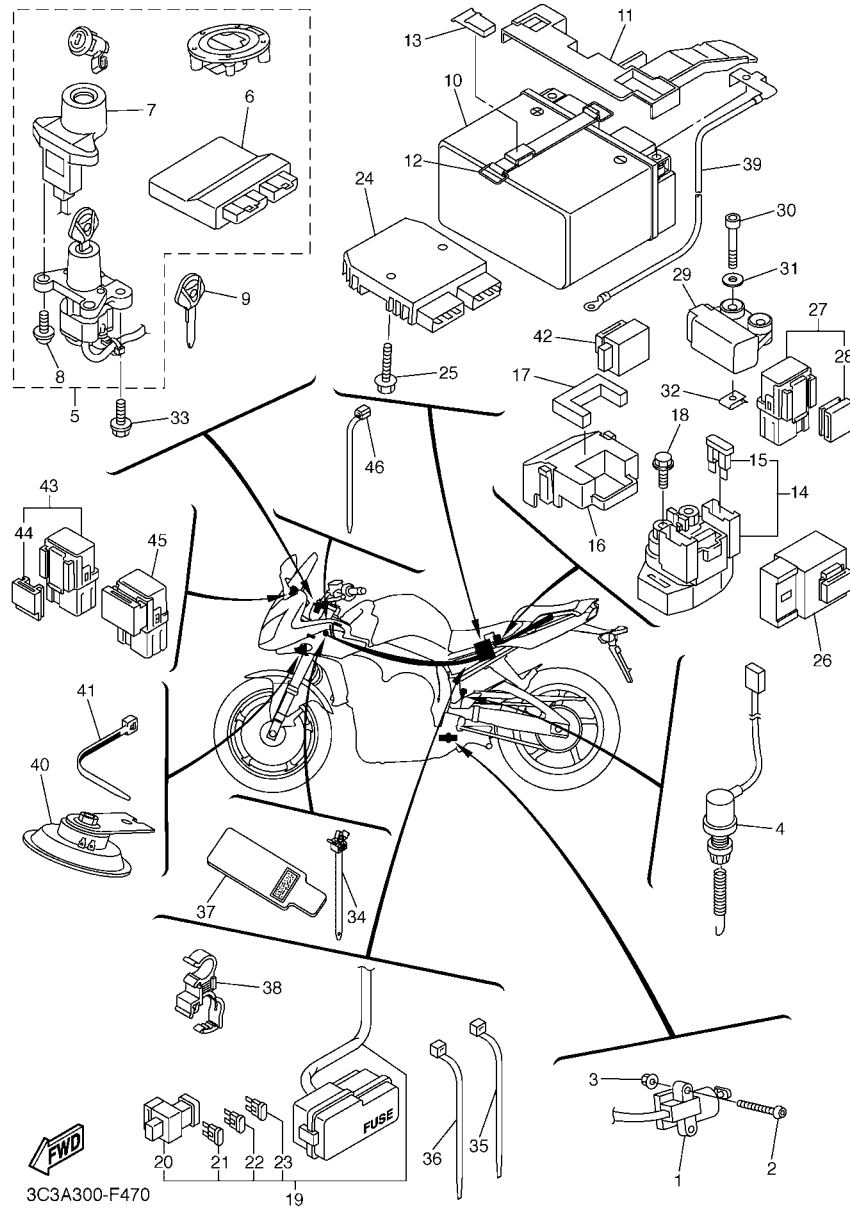

FIG. 47 ELECTRICAL 2

REF. NO.	PART NO.	DESCRIPTION	3C3A	3C3B	3C3C	REMARKS
1	5VS-82566-61	SWITCH, SIDE STAND	1	1	1	
2	92017-05030	BOLT, BUTTON HEAD	2	2	2	
3	95607-05200	NUT, U FLANGE	2	2	2	
4	2D1-82530-00	STOP SWITCH ASSY	1	1	1	
5	2D1-W8250-01	MAIN SW. IMMOBILIZER KIT	1		1	
	2D1-W8250-11	MAIN SW. IMMOBILIZER KIT		1		
6	2D1-8591A-01	.ENGINE CONTROL UNIT ASSY	1		1	
	2D1-8591A-11	.ENGINE CONTROL UNIT ASSY		1		
7	2D1-8255P-00	.IMMOBILIZER. UNIT COMP.	1	1	1	
8	5SL-82113-00	.SCREW	2	2	2	
9	5SL-82511-08	BLANK KEY	1	1	1	AP
10	2D1-82100-00	BATTERY ASSY(GS YUASA YTZ14S)	1	1	1	
11	2D1-82129-00	COVER, BATTERY	1	1	1	
12	2D1-82131-00	BAND, BATTERY	1	1	1	
13	5YU-2162A-00	HOOK	1	1	1	
14	2C0-81940-00	STARTER RELAY ASSY	1	1	1	
15	36Y-82151-00	.FUSE (15A-BL)	2	2	2	
16	5SL-82119-10	COVER, LEAD WIRE	1	1	1	
17	2D1-82176-00	DAMPER	1	1	1	
18	95027-06008	BOLT, FLANGE	2	2	2	
19	3C3-82590-00	WIRE HARNESS ASSY	1	1	1	
20	5JW-82151-10	.FUSE (50A)	1	1	1	
21	5JJ-82151-70	.FUSE (25A-BL)	2	2	2	
22	5JJ-82151-10	.FUSE (15A-BL)	2	2	2	
23	5JJ-82151-30	.FUSE (10A-BL)	6	6	6	
24	1D7-81960-00	RECTIFIER & REGULATOR ASSY	1	1	1	
25	95822-06025	BOLT, FLANGE	2	2	2	

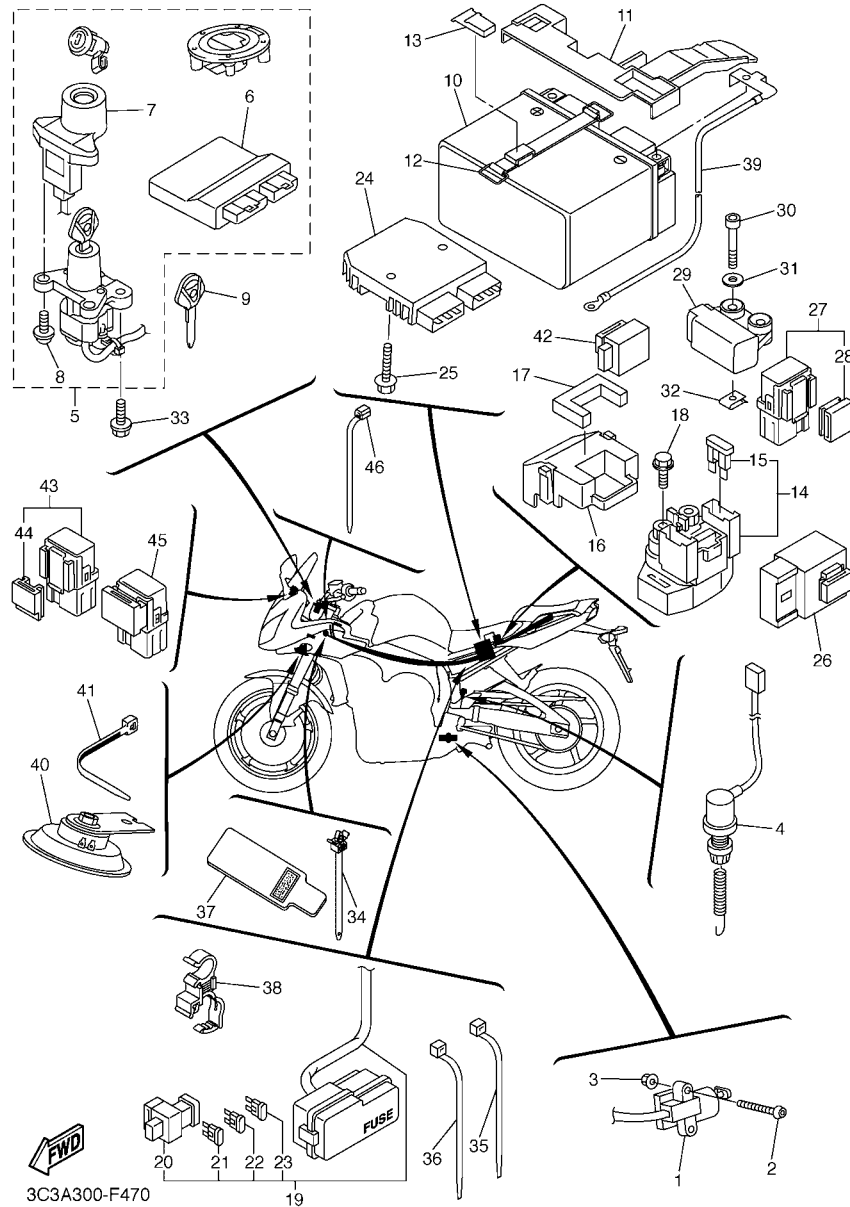

FIG. 47 ELECTRICAL 2

REF. NO.	PART NO.	DESCRIPTION	3C3A	3C3B	3C3C	REMARKS
26	5VK-81950-40	RELAY ASSY	1	1	1	
27	5JJ-81950-20	RELAY ASSY	1	1	1	
28	5JJ-81952-00	.HOLDER, RELAY	1	1	1	
29	5PS-82576-01	LEAN ANGLE SENSOR	1	1	1	
30	91317-04025	BOLT	2	2	2	
31	90201-047A2	WASHER, PLATE	2	2	2	
32	90183-04039	NUT, SPRING	2	2	2	
33	90109-080G5	BOLT	2	2	2	
34	90464-12036	CLAMP	2	2	2	
35	1UA-82591-00	BAND	2	2	2	
36	90464-13073	CLAMP	3	3	3	
37	2D1-82589-00	PROTECTOR, WIRE HARNESS	1	1	1	
38	90464-12012	CLAMP	1	1	1	
39	2D1-82116-00	WIRE, MINUS LEAD	1	1	1	
40	2D1-83371-00	HORN	1	1	1	
41	3MA-82591-00	BAND	1	1	1	
42	4GY-83350-00	FLASHER RELAY ASSY	1	1	1	
43	5EA-81950-20	RELAY ASSY	1	1	1	
44	5EA-81952-00	.HOLDER, RELAY	1	1	1	
45	5DM-81950-00	RELAY ASSY	1	1	1	
46	90464-13077	CLAMP	1	1	1	

NUMERICAL INDEX

PART NO.	GRID NO.	PART NO.	GRID NO.	PART NO.	GRID NO.	PART NO.	GRID NO.	PART NO.	GRID NO.	PART NO.	GRID NO.
2D1-11026-00	B - 3	3FV-12153-20	B - 7	5VY-1243A-00	B - 11	5VY-13596-00	B - 15	5VY-14905-00	C - 3	2D1-16370-00	C - 10
5VY-11101-20	B - 2	3LN-12153-20	B - 7	2D1-1243E-00	B - 11	5VY-13597-00	B - 15	5DM-14936-00	C - 2	2D1-16382-00	C - 10
5VY-11111G-00	B - 2	3FV-12153-30	B - 7	5VY-1243F-00	B - 11	5VY-13598-00	B - 15	22U-14952-00	C - 2	5VY-16383-00	C - 10
5VY-11133-10	B - 2	3LN-12153-30	B - 7	5VY-12443-10	C - 8	2D1-13750-00	C - 2	5PS-14987-00	C - 2	5VY-16384-00	C - 10
5VY-11134-10	B - 2	1HX-12168-00	B - 6	2D1-1244G-00	B - 11	5VY-13761-00	C - 3	4C8-15100-00	C - 6	4X7-16385-00	C - 10
5VY-11165-00	C - 8	1HX-12168-20	B - 6	5VY-12450-11	B - 9	5VY-13898-00	B - 13	4B1-15113-00	C - 8	2D1-17121-10	C - 12
2D1-11181-00	B - 2	1HX-12168-40	B - 6	5VY-12456-10	B - 9	2D1-13907-01	D - 14	5EB-15155-00	C - 6	2D1-17131-00	C - 12
5VY-11191-02	B - 2	1HX-12168-60	B - 6	2D1-12461-00	B - 11	2D1-13971-00	C - 3	5VY-15163-00	C - 12	2D1-17151-00	C - 12
5VY-11193-10	B - 2	1HX-12168-80	B - 6	22W-12462-00	B - 11	5PW-14103-00	C - 3	5VY-15164-00	C - 7	2D1-17161-00	C - 12
214-11198-01	B - 14	1HX-12168-A0	B - 6	2D1-12464-00	B - 12	5JW-14104-00	C - 3	36Y-15189-00	C - 8	5VY-17211-00	C - 13
5VY-11311-10	B - 4	1HX-12168-F0	B - 6	2D1-12467-00	B - 12	4KM-14137-00	C - 2	4H7-15189-00	C - 8	2D1-17221-00	C - 12
2D1-1133E-00	C - 5	1HX-12168-H1	B - 6	5VY-12469-00	B - 9	5PS-14147-00	C - 3	5PX-15189-00	C - 7	5VY-17231-00	C - 13
2D1-1133F-10	C - 5	1HX-12168-K1	B - 6	5GV-1246A-00	B - 11	5VY-14171-00	C - 2	4C8-15191-00	F - 2	5VY-17241-00	C - 12
5VY-11351-00	B - 4	1HX-12168-M1	B - 6	5VY-12481-10	B - 10	5VY-14204-00	C - 2	5VY-15316-00	C - 6	2D1-17251-01	C - 13
2D1-11411-00	B - 5	1HX-12168-R1	B - 6	2D1-12484-00	B - 10	8CC-14216-10	C - 2	5PW-15361-00	C - 6	2D1-17261-00	C - 12
5VY-11416-00	B - 5	1HX-12168-U1	B - 6	4XV-12485-00	B - 9	3XV-14251-00	C - 2	3F9-15362-00	C - 7	5VY-17402-00	C - 12
5VY-11416-10	B - 5	1HX-12168-W1	B - 6	5VY-12485-10	B - 11	5PW-14251-00	C - 2	2D1-15393-00	B - 15	5VY-17411-00	C - 12
5VY-11416-20	B - 5	1HX-12168-Y1	B - 6	1AA-12535-00	B - 11	5PW-14349-00	C - 2	5VY-15411-00	C - 7	5VY-17442-00	C - 12
5VY-11416-30	B - 5	1HX-12169-11	B - 7	2D1-12551-00	B - 12	5SL-14349-00	C - 2	2D1-15413-00	C - 8	5VY-17446-00	C - 12
5VY-11416-A0	B - 5	1HX-12169-31	B - 7	5VY-12576-00	B - 9	5FL-14349-10	C - 2	2D1-15416-00	C - 7	3CV-17460-00	C - 13
5VY-11445-00	C - 9	1HX-12169-50	B - 7	2D1-12578-00	B - 11	5JW-14396-00	C - 2	2D1-15418-00	C - 7	2D1-18101-00	C - 15
5VY-11478-00	C - 9	1HX-12169-70	B - 7	5VY-12579-00	B - 11	2D1-14409-00	B - 15	2D1-15421-00	C - 7	2D1-18110-00	C - 15
2D1-11537-00	C - 9	1HX-12169-90	B - 7	5VY-12588-00	B - 10	2D1-1440B-00	B - 15	5VY-15431-00	C - 8	2D1-18112-00	C - 15
5VY-11549-00	B - 5	1HX-12169-E0	B - 7	2D1-12589-00	B - 12	2D1-14411-00	B - 15	2D1-15441-00	C - 8	5EB-18113-00	C - 15
5VY-11603-01	B - 5	1HX-12169-G0	B - 7	2D1-12637-00	B - 9	2D1-14413-00	C - 3	2D1-15451-10	C - 7		E - 13
5VY-11631-10	B - 5	1HX-12169-J0	B - 7	2D1-12675-00	B - 11	2D1-14421-00	B - 15	4C8-15456-00	C - 8	2D1-18115-00	C - 15
5VY-11633-00	B - 5	1HX-12169-L0	B - 7	5EB-12822-00	B - 14	2D1-14451-00	B - 15	4C8-15461-00	C - 7	5VX-18116-00	C - 15
4C8-11650-00	B - 5	1HX-12169-N0	B - 7	5VY-13117-10	B - 13	2D1-14452-00	B - 15	4C8-15462-00	C - 8	5VY-18127-10	C - 15
5VY-11654-01	B - 5	1HX-12169-T0	B - 7	2D1-13160-00	C - 2	5VY-14457-00	B - 15	5VY-15515-00	C - 9	5VY-18140-00	C - 15
2D1-11656-00	B - 5	2D1-12170-00	B - 8	5VY-13161-00	B - 14	2D1-14462-00	B - 15	5VY-15517-00	C - 9	5VY-18144-00	C - 15
2D1-11656-10	B - 5	5VY-12176-00	B - 8	5VY-1316E-00	B - 13	2D1-14498-00	B - 15	5VY-15521-00	C - 9	5VX-18154-00	C - 15
2D1-11656-20	B - 5	2D1-12180-00	B - 8	5VY-13310-10	B - 9	5JW-14589-00	C - 2	5VY-15542-00	C - 7	2D1-18511-00	C - 14
2D1-11656-30	B - 5	5VY-12210-20	B - 8	5VY-13336-00	B - 9	2D1-14602-00	C - 5	5VY-15570-00	C - 9	2D1-18512-00	C - 14
5VY-12111-00	B - 6	2D1-12213-00	B - 8	5VY-13354-00	C - 11	4FM-14613-00	C - 5	5VY-15586-00	C - 9	5VY-18513-01	C - 14
5VY-12112-00	B - 6	5BE-12241-00	B - 2	5VY-13355-00	B - 9	2D1-14703-00	C - 5	5VY-15589-00	F - 9	5VY-18531-00	C - 14
2D1-12113-00	B - 6	5VY-12251-00	B - 8	5VY-13410-00	B - 13	2D1-14718-10	C - 5	5VY-16150-00	C - 10	5VY-18535-00	C - 14
2D1-12114-00	B - 6	5VY-12252-00	B - 8	4C8-13414-00	B - 14	5JW-14723-00	C - 4	5VY-16154-00	C - 10	5VY-18536-00	C - 14
5NL-12116-00	B - 6	5VY-12277-00	D - 12	5VY-13416-00	B - 13	2D1-14737-00	C - 5	5VY-16155-00	C - 9	5VY-18540-00	C - 14
1HX-12117-00	B - 6	2D1-12405-00	B - 11	2D1-13417-10	B - 14	5VY-14755-00	C - 5	5VY-16164-00	C - 11	136-18542-00	C - 14
1WG-12117-00	B - 6	2D1-12405-10	B - 11	5VY-13418-10	C - 6	2D1-14799-00	C - 5	5VY-16181-00	C - 11	5VY-18562-00	C - 14
1HX-12118-00	B - 6	3C3-1240J-00-P0	B - 12	5GH-13440-20	B - 14	2D1-14826-00	C - 5	5VY-16321-00	C - 10	2D1-21110-00-P0	D - 2
1WG-12118-00	B - 6	3C3-1240K-00-P0	B - 12	5VY-13470-00	B - 14	5VY-1482K-00	B - 2	5VY-16325-00	C - 10	2D1-21110-10-P0	D - 2
4SV-12119-00	B - 6	2D1-12410-00	B - 11	5JW-13473-00	B - 14	2D1-14840-00	C - 4	5VY-16330-00	C - 10	2D1-2117G-00	D - 2
4TV-12119-00	B - 6	5LP-12411-00	B - 11	5EB-13475-00	B - 14	5VY-14881-00	C - 4	5VY-16331-00	C - 10	4XV-2117K-00	E - 2
5VY-12121-00	B - 6	5VY-12421-01	B - 9	5VY-13490-00	B - 14	5VY-14882-00	C - 4	5VY-16340-00	C - 10	2D1-2117N-00	D - 2
3GM-12126-00	B - 6	5VY-12422-00	B - 9	5VY-13543-00	C - 3	5VY-14883-00	C - 4	132-16346-00	C - 15	3C3-2118N-00	D - 6
3FV-12153-09	B - 7	11H-12438-10	B - 9	8FP-13556-00	C - 3	5SL-14890-10	B - 2	5VY-16351-00	C - 10	2D1-21190-00-P0	D - 2
3LN-12153-09	B - 7	4XV-12439-00	B - 9	5VY-13595-00	B - 15	5VY-14899-00	B - 2	4XV-16356-01	C - 10	3C3-21261-00	D - 6

NUMERICAL INDEX

PART NO.	GRID NO.	PART NO.	GRID NO.	PART NO.	GRID NO.	PART NO.	GRID NO.	PART NO.	GRID NO.	PART NO.	GRID NO.
2D1-21268-10	D - 3	2D1-2217M-00	D - 8	2D1-2414K-00	D - 15	4BP-24792-00	E - 2	5VS-2589F-00	E - 9	2D1-27443-00	E - 11
2D1-21287-01	D - 2	2D1-22184-00	D - 8	2D1-2414N-00	D - 15	4XV-25117-00	E - 3	5VS-2589H-00	E - 9	2D1-27486-00	E - 10
3C3-21341-01	E - 2	2D1-22210-01	D - 10	2D1-2414P-00	D - 15	5VY-25168-00-98	E - 3	5SL-25914-00	E - 7	2D1-27487-00	E - 11
2D1-21345-00	D - 2	5SL-22311-00	D - 8	2D1-2414R-00	D - 15	4XV-25181-10	E - 3	5DH-25916-00	E - 7	3C3-274A3-00	E - 12
3YX-21376-00	D - 2	3C3-22825-00	D - 5	3ME-2415E-01	D - 15	5PW-25317-00	E - 5	3JD-25917-00	E - 7	2D1-28100-00	D - 6
4XV-21376-00	D - 4	3C3-22826-00	D - 5	2D1-24181-00	D - 15	5VY-25338-00-98	E - 5	5SL-25917-00	E - 7	3P6-28307-00	E - 14
2D1-2139U-00	B - 12	2D1-23102-11	D - 12	3MA-24181-00	C - 5	5VX-25364-00	E - 5	4SV-25919-00	E - 4	3C3-28315-00	E - 14
2D1-2144G-00	E - 11	2D1-23103-11	D - 12	5VX-24181-00	D - 14	2D1-25366-00	E - 5	5SL-25919-00	E - 7	3C3-28315-30	E - 14
5EB-21495-00	D - 2	2D1-23110-00	D - 12	5VY-24181-00	D - 14	2D1-25377-00	E - 5	5VX-25921-50	E - 7	2D1-28345-01	D - 15
5PW-21511-00-P6	D - 4	2D1-23111-10	D - 12	2D1-24182-00	D - 4	2D1-25381-00	E - 5	4SV-25924-00	E - 4	3C3-2834E-00	E - 15
5PW-21511-00-PA	D - 4	5VY-23118-00	D - 12	2D1-24183-00	D - 2	2D1-25383-00	E - 5	8CR-25924-00	E - 7	4XV-2834E-00	D - 15
3C3-21541-00	D - 4	2D1-23120-00	D - 12	2D1-24184-00	D - 2	5VY-25388-00	E - 5	3GM-25925-00	E - 4		E - 14
5PA-21568-00	D - 15	4KM-23123-01	D - 13	2D1-24185-00	D - 2	5VY-25389-00	E - 5	5SL-25926-00	E - 7	3C3-2834F-00	E - 15
2D1-21575-00	D - 3	2D1-23136-10	D - 12	2D1-24192-00	D - 14	5MT-25398-00	E - 3	2D1-26111-01	E - 8	3C3-28356-00	E - 15
3C3-21611-00	D - 6	2D1-23141-00	D - 12	2D1-24315-00	D - 14		E - 5	4YR-26240-02	E - 8	3C3-2835U-00	E - 15
3C3-21617-00	D - 5	4PU-23144-00	D - 12	2D1-24316-00	D - 14	5MT-25398-10	E - 3	4YR-26241-02	E - 8	3C3-2835V-00	E - 15
2D1-21629-00	D - 5	4PU-23145-01	D - 12	2D1-24317-00	D - 14		E - 5	51J-26246-01	E - 8	3C3-2836A-00	E - 15
2D1-21629-10	D - 5	4V4-23146-L0	D - 12	68V-24376-00	C - 2	5MT-25398-20	E - 3	3C3-26280-00	E - 15	4KN-2836B-00	D - 6
5YU-2162A-00	F - 11	3XJ-23147-L0	D - 12	5JW-24486-00	D - 14		E - 5	3LN-26281-01	E - 8	3C3-2836E-00	E - 15
2D1-21639-00	D - 5	4V4-23153-L0	D - 12	2D1-24491-00	D - 14	2D1-25445-20	E - 5	4BP-26282-00	E - 8	3C3-2836K-00	E - 14
5YU-21639-00	D - 2	509-23158-L0	D - 12	5JJ-24602-00	D - 14	2D1-2580T-00	E - 4	3C3-26290-00	E - 15	3C3-2836L-00	E - 14
3C3-2163A-00	D - 5	2D1-23170-01	D - 12	2D1-24665-00	E - 2	2D1-2580U-00	E - 4	3C3-26298-00	E - 15	3C3-28371-01	E - 14
2D1-21646-00	D - 4	2D1-23170-11	D - 12	2D1-24710-00	E - 2	2D1-2580W-00	E - 7	2D1-26302-00	E - 8	3C3-28372-00	E - 14
2D1-21650-00	D - 9	3D8-23181-00	D - 12	2D1-24711-00	E - 2	5D0-2581T-00	E - 4	5VS-26332-00	E - 9	3C3-2837J-00	E - 14
5VY-21668-00	D - 9	3C3-23318-00	D - 11	3C3-2471K-00-P0	D - 4	5SL-25827-00	E - 7	3C3-26335-00	E - 8	3C3-28381-00	E - 14
2D1-21688-00	D - 5	3C3-23319-00	D - 11	3C3-2471K-00-P2	D - 5	5SL-25827-10	E - 7	3C3-27111-00	E - 12	3C3-28381-10	E - 14
5VY-21688-00	D - 6	2D1-23340-00	D - 13	3C3-2471K-00-P3	D - 4	5SL-25828-00	E - 7	278-27114-00	E - 2	3C3-283B1-00	E - 14
5VY-21689-00	D - 6	3LC-23357-00	D - 12	3C3-24723-00	D - 4	2D1-2582A-00	E - 13	371-27114-00	E - 12	3C3-283B1-10	E - 14
2D1-216A2-00	D - 4	3C3-23378-00	E - 9	3C3-24724-00	D - 4	2D1-2582W-00	E - 7	5VX-27114-00	E - 10	2D1-81410-01	F - 2
2D1-216A3-00	D - 4	2D1-23405-00	D - 11	4HM-24728-00	E - 2	5SL-25838-00	E - 7	3C3-27151-01	E - 12	5VY-81450-00	F - 2
2D1-21711-00	D - 7	4XV-23415-01	D - 11	3C3-2472K-00-P0	D - 5	2D1-2583V-00	E - 13	3C3-27152-00	E - 12	5VY-81670-01	F - 9
2D1-21719-00	D - 7	4XV-23418-00	D - 11	3C3-2472K-00-P2	D - 5	5SL-25852-00	E - 13	2D1-27211-00	E - 13	2D1-81673-00	F - 9
3C3-2171A-00-P0	D - 14	4XV-2341B-00	D - 11	3C3-2472K-00-P3	D - 5	5VS-25852-00	E - 9	4BP-27222-01	E - 13	3AJ-81801-00	F - 3
3C3-2171A-00-P3	D - 15	4PX-23426-00	D - 3	3C3-24737-00	D - 4	5SL-25854-00	E - 13	2D1-27311-00	E - 10	2D1-81815-00	F - 3
2D1-21721-00	D - 7	3VD-23434-00	D - 11	22W-24741-00	D - 5	5VS-25854-00	E - 9	2D1-27321-00	E - 10	2D1-81826-00	F - 3
5PW-2174X-00	D - 5	2D1-23441-00	D - 11	3C3-24741-00	E - 2	5SL-25855-00	E - 13	2D1-27410-00	E - 10	4XV-8182A-00	F - 3
2D1-2174Y-00	D - 2	2D1-23442-00	D - 11	3C3-24747-00	D - 4	5VS-25855-00	E - 9	4BP-27413-00	E - 10	11H-81844-00	F - 3
26H-21828-00	D - 7	5YU-23445-00	D - 11	3C3-24750-00	E - 2	4BP-2585F-00	E - 13	1HX-27415-00	E - 10	1FK-81847-00	F - 3
2D1-21871-00	D - 7	3FV-23462-00	D - 11	3C3-24751-00	E - 2	3LN-2585G-00	E - 13	2D1-2741L-00	E - 11	2D1-81890-00	F - 3
5VY-21875-00	D - 7	5JW-23844-00	E - 14	2D1-2476U-00	E - 2	5VS-25867-00	E - 9	2D1-27420-00	E - 10	2C0-81940-00	F - 11
3C3-2193A-00	D - 5	2D1-23857-00	E - 9	2D1-2476V-00	E - 2	3C3-25872-00	E - 9	1NL-27424-00	E - 10	5DM-81950-00	F - 12
2D1-2197E-00	D - 3	2D1-24106-00	D - 15	3C3-24773-00-P0	D - 4	2D1-25874-00	E - 13	36Y-27424-01	E - 12	5EA-81950-20	F - 12
2D1-22110-11	D - 8	2D1-24108-00	D - 15	3C3-24773-00-P2	D - 4	2D1-25875-00	E - 9	2D1-27425-02	D - 3	5JJ-81950-20	F - 12
2D1-22217-00	D - 8	2D1-24129-00	D - 3	3C3-24773-00-P3	D - 4	2D1-25876-00	E - 9	2D1-2742L-00	E - 11	5VK-81950-40	F - 12
5JJ-22128-00	D - 8	2D1-2412G-00	D - 14	4BP-24780-00	E - 2	2D1-25886-00	E - 13	3VR-27431-01	E - 11	5EA-81952-00	F - 12
2D1-222141-00	D - 9	2D1-24139-00	D - 3	2D1-24780-02	E - 2	2D1-25887-00	D - 8	5VX-27437-00	E - 11	5JJ-81952-00	F - 12
2D1-222151-00	D - 8	5SL-2413B-00	D - 15	2D1-24785-00	E - 2	2D1-25894-00	E - 13	3VR-27441-01	E - 11	1D7-81960-00	F - 11
2D1-2217A-00	D - 8	2D1-2414H-00	D - 15	2D1-2478E-00	E - 2	2D1-25895-00	E - 13	2D1-27442-00	E - 10	2D1-82100-00	F - 11

NUMERICAL INDEX

PART NO.	GRID NO.	PART NO.	GRID NO.	PART NO.	GRID NO.	PART NO.	GRID NO.	PART NO.	GRID NO.	PART NO.	GRID NO.
5SL-82113-00	F - 11	5JJ-83913-00	F - 8	2D1-W8250-01	F - 11	90110-05112	D - 14	90149-06064	C - 7	90201-08057	E - 6
2D1-82116-00	F - 12	5VS-83922-00	E - 9	2D1-W8250-11	F - 11	90110-06102	D - 8	90149-06067	F - 2	90201-08083	E - 13
5SL-82119-10	F - 11	2C0-83945-00	F - 8	3C3-Y283G-80-P4	E - 14	90110-06108	C - 8	90149-06165	D - 7	90201-10008	D - 2
2D1-82122-10	D - 4	5LV-83951-00	F - 8	3C3-Y283G-90-P4	E - 14	90110-06110	C - 5	90149-06302	E - 9	90201-10021	E - 5
2D1-82129-00	F - 11	3C3-83969-00	F - 8	3C3-Y283G-A0-P4	E - 14	90110-06112	C - 7	90149-08009	D - 7	90201-10029	C - 11
2D1-8212B-01	D - 4	2D1-83975-00	F - 8	3C3-Y283G-B0-P4	E - 14	90110-06161	B - 10	90150-04041	D - 6	90201-10033	B - 2
18G-82131-00	E - 2	4HM-83980-00	E - 9	3C3-Y283G-G0-P0	E - 14		B - 13	90150-05024	E - 14	90201-10039	F - 9
2D1-82131-00	F - 11	3C3-84310-00	F - 6	3C3-Y283G-H0-P0	E - 14		C - 6	90151-06022	C - 8	90201-10141	D - 11
36Y-82151-00	F - 11	3C3-84310-10	F - 6	3C3-Y283W-10	E - 14		F - 9	90153-06002	B - 10	90201-101J1	E - 10
5JJ-82151-10	F - 11	3C3-84312-00	F - 6	2D1-YK241-00-P3	D - 14	90110-06164	C - 12	90154-05007	E - 14	90201-10669	E - 12
5JW-82151-10	F - 11	8V0-84314-00	F - 6	2D1-YK241-00-P4	D - 14	90110-06167	B - 9	90154-05012	D - 14	90201-12575	C - 15
5JJ-82151-30	F - 11	4SV-84347-00	F - 6	2D1-YK241-00-P5	D - 14	90110-06168	B - 11	90157-05025	E - 10	90201-12790	F - 9
5JJ-82151-70	F - 11	3C3-84359-00	F - 6	90101-08013	E - 6		C - 8	90157-10001	D - 2	90201-16020	E - 10
2D1-82176-00	F - 11	5LV-84397-00	F - 6	90101-10004	E - 12	90110-06173	B - 13	90159-05011	F - 7	90201-18013	D - 9
2D1-82309-00	F - 9	2D1-84710-00	F - 7	90101-10006	E - 10	90110-06174	B - 10	90159-05083	D - 5	90201-20016	C - 9
5VY-82310-00	F - 9	1A2-84714-41	F - 7	90105-06026	B - 2	90110-06175	F - 9	90159-06026	C - 10	90201-20017	C - 9
1C7-82380-00	C - 2	2D1-84735-00	F - 7	90105-06050	D - 11	90110-06176	C - 9	90164-05014	F - 5	90201-25020	E - 6
2C0-82380-00	F - 9	3C3-84736-00	F - 7	90105-06065	B - 9	90110-06178	B - 2		F - 6	90201-257H0	C - 13
2D1-82386-00	C - 2	2D1-84737-00	F - 7	90105-06066	B - 9	90110-06182	B - 13		F - 7	90201-281U8	D - 11
5SL-82511-08	F - 11	4HC-84744-00	F - 7	90105-06078	F - 2		B - 14	90170-06228	C - 15	90202-05088	D - 15
2D1-82530-00	F - 11	2D1-84745-00	F - 7	90105-06556	E - 9		C - 8	90170-08010	E - 13	90202-05224	D - 15
3GB-82540-01	F - 9	5SL-85110-00	D - 6	90105-07006	B - 8		C - 14	90176-06014	B - 11	90202-06170	E - 15
2D1-8255P-00	F - 11	3Y6-85130-02	D - 6	90105-08101	C - 6	90110-06200	E - 15	90176-10075	B - 2	90202-30235	D - 11
5VS-82566-61	F - 11	5VY-85720-00	F - 9	90105-08447	D - 5	90110-06233	D - 15	90176-28083	D - 11	90206-17084	E - 10
5PS-82576-01	F - 12	8CC-85790-01	F - 9	90105-10030	D - 8	90110-06255	C - 7	90179-05003	D - 15	90208-20001	C - 10
2D1-82589-00	F - 12	2D1-85820-00	F - 9	90105-10290	F - 9	90110-08068	C - 7	90179-05523	E - 14	90209-08295	E - 10
3C3-82590-00	F - 11	5VY-85829-00	F - 9	90105-10323	D - 9	90110-08071	E - 10	90179-08410	C - 5	90209-25011	C - 12
1UA-82591-00	D - 2	5VY-85850-00	C - 2		D - 10	90110-10005	D - 2	90179-10006	B - 2	90209-28008	C - 12
	F - 12	5FL-85885-02	C - 2	90105-10638	E - 4	90110-10010	E - 10	90179-10696	D - 2	90214-25003	C - 12
3MA-82591-00	E - 9	8FP-85886-00	B - 15	90109-05005	B - 15	90111-05015	E - 10	90179-20007	C - 10	90214-25004	C - 12
	F - 12	5VY-85896-00	F - 9	90109-06014	C - 8	90111-05019	D - 15	90179-22011	C - 13	90214-28002	C - 13
4XV-82910-15	F - 8	2D1-8591A-01	F - 11	90109-06015	B - 12	90111-05024	D - 15	90179-30691	D - 11	90214-29002	C - 12
4XV-82917-01	F - 8	2D1-8591A-11	F - 11		C - 8	90111-06019	C - 15	90183-04039	F - 12	90215-30233	C - 13
5PW-83310-01	F - 4	2D1-8592A-00	C - 5	90109-06016	C - 7		D - 3	90183-05024	D - 5	90240-08124	E - 13
1KH-83311-00	F - 4	2D1-W0041-00	E - 9	90109-06031	C - 7	90111-06031	B - 12	90183-05076	E - 14	90269-06001	D - 2
2D1-83318-00	F - 4	5VX-W0042-50	E - 13		D - 4	90111-06043	D - 4	90183-06053	E - 15	90269-06003	D - 3
5PW-83320-01	F - 4	5SL-W0045-00	E - 4	90109-06100	C - 6	90111-06060	C - 5	90185-10009	E - 5	90269-06008	E - 15
2D1-83330-20	F - 4	5VX-W0046-00	E - 7	90109-063F1	D - 4	90111-06079	B - 12	90185-10037	E - 10	90269-07007	D - 8
5PW-8333A-00	F - 4	5SL-W0047-00	E - 7	90109-066F0	B - 2	90111-06080	B - 12	90185-18167	D - 9	90269-07008	D - 8
2D1-83340-20	F - 4	3GM-W0047-10	E - 4	90109-067E6	B - 12	90116-10023	C - 6	90185-24007	E - 5	90269-07076	D - 5
5PW-8334A-00	F - 4	3MA-W0047-10	E - 4	90109-080G5	F - 12	90116-10032	C - 6	90201-047A2	F - 12	90269-07077	D - 4
4GY-83350-00	F - 12	1J3-W0048-00	E - 4	90109-08170	C - 5	90116-10485	E - 5	90201-05017	C - 5	90282-03001	F - 9
2D1-83371-00	F - 12	1UY-W0048-00	E - 7	90109-08174	E - 10	90119-05020	E - 13	90201-05725	D - 6	90338-08163	D - 11
2D1-83500-40	F - 5	4SV-W0057-00	E - 4	90109-085G6	E - 12	90119-06228	D - 7	90201-06034	B - 2	90340-12003	C - 8
2D1-83500-50	F - 5	5SL-W0057-00	E - 7	90109-101E6	E - 12	90119-09003	C - 6	90201-06079	B - 10	90340-14132	B - 14
3C3-83513-00	F - 5	4SV-W0057-10	E - 4	90109-103A9	E - 10	90149-06006	E - 2	90201-060A3	D - 14	90340-18002	B - 2
4XV-83755-02	F - 9	2TV-W2470-00	E - 2	90109-105G7	E - 12	90149-06026	D - 2	90201-06431	C - 7	90340-32004	C - 7
4XV-83912-11	F - 8	3C3-W2587-00	E - 9	90110-05014	D - 14	90149-06043	E - 4	90201-06589	C - 9	90387-05031	F - 7

NUMERICAL INDEX

PART NO.	GRID NO.	PART NO.	GRID NO.	PART NO.	GRID NO.	PART NO.	GRID NO.	PART NO.	GRID NO.	PART NO.	GRID NO.
90387-06009	D - 8	90450-35001	B - 11	90480-14013	D - 3	92990-03100	C - 2	93317-42599	D - 8	95702-06500	E - 2
90387-0600V	D - 9	90450-38040	B - 9	90480-14229	F - 6	92990-06600	C - 5	93399-99932	D - 11	95702-08500	D - 5
90387-06026	D - 3		B - 11	90480-14604	C - 5	93102-12106	C - 15	93399-99957	D - 11	95707-05500	D - 6
90387-06112	B - 10	90450-62002	B - 15	90480-15363	B - 11	93102-12372	B - 9	93420-61M07	E - 5	95707-06500	E - 9
90387-06130	D - 8	90461-10010	D - 14	90480-18276	F - 7	93102-15212	C - 10	93440-28184	C - 12		E - 15
90387-061W6	D - 14	90462-08057	F - 9	90480-20001	D - 7	93102-40330	C - 13	93440-31187	C - 12	95807-06010	E - 15
90387-062M9	D - 7	90464-04001	C - 5	90501-064L1	C - 14	93106-28043	E - 3	93440-52009	C - 13	95807-06012	B - 12
90387-062Y6	D - 15	90464-07259	D - 4	90501-12743	E - 11	93106-40013	E - 5	93440-62032	C - 13	95812-06050	C - 6
90387-064T3	E - 15	90464-07M40	D - 7	90501-230A0	C - 10	93109-17071	D - 8	93450-18157	B - 5	95812-06060	C - 6
90387-065J6	D - 4	90464-10008	E - 8	90506-18008	E - 10	93210-04092	C - 6	93501-04011	E - 11	95812-06070	C - 6
90387-06M60	C - 5	90464-12012	F - 12	90506-20014	E - 13	93210-06667	B - 10	93603-12007	B - 9	95812-08016	D - 3
90387-07391	B - 12	90464-12036	F - 12	90506-23010	E - 12		B - 13	93603-17070	B - 9	95812-08050	C - 6
90387-0804S	C - 15	90464-13073	B - 11	90506-40007	E - 12	93210-09165	B - 13	93605-10108	C - 7	95812-08060	C - 6
90387-09003	D - 5		F - 12	90508-18051	C - 10	93210-14003	B - 13	93607-44002	B - 8	95814-08030	C - 5
90387-10043	D - 9	90464-13077	F - 12	90508-32020	C - 15		C - 6	93610-20189	C - 7	95814-10040	E - 12
	D - 10	90464-16021	D - 5	91312-06025	B - 14	93210-15566	B - 14	93900-00030	E - 3	95817-06012	E - 9
90387-10050	E - 10	90464-17003	D - 8	91312-06040	B - 9	93210-16325	C - 8		E - 5	95817-06025	D - 6
90387-1012A	D - 8	90464-20003	E - 14	91312-06080	F - 3	93210-18397	C - 9	94112-17094	E - 3	95822-06014	D - 5
	D - 10	90464-20191	E - 8	91314-06020	B - 8	93210-22298	B - 13	94119-17062	E - 5	95822-06025	F - 11
90387-10636	E - 12	90464-23002	B - 12	91314-06105	B - 2	93210-22382	C - 7	94580-25078	B - 13	95822-08025	D - 5
90387-1211D	C - 15	90464-28003	C - 4	91314-08030	D - 11	93210-235A1	B - 10	94582-10122	E - 6	95822-08030	D - 5
90387-22002	E - 3	90464-30040	C - 3		D - 13		B - 11	94591-60122	B - 8	95827-06020	D - 6
90387-25007	C - 12	90464-51001	F - 9	91314-08040	D - 13	93210-27194	C - 7	94682-05031	E - 6		E - 2
90387-25008	C - 13	90464-62085	E - 14	91317-04025	F - 12	93210-27370	B - 10	94701-00403	B - 2	95827-06025	D - 5
90387-28001	E - 5	90465-08053	F - 9	91317-05010	D - 14	93210-32172	C - 7	95022-06016	F - 9	95827-08035	E - 15
90387-28003	C - 12	90465-08054	F - 9	91317-05020	E - 8	93210-357A2	B - 9	95022-06020	C - 15	97702-50025	B - 15
90387-28004	C - 12	90467-08075	D - 7	91317-05025	E - 8	93210-47675	B - 9	95024-06012	B - 2	97702-50514	F - 9
90387-31003	C - 12	90467-09006	D - 14	91317-06016	D - 14	93210-49046	B - 11	95024-06025	B - 9	97702-50520	B - 15
90401-10172	E - 9	90467-11090	B - 11	91317-06090	D - 14	93210-57003	C - 8	95024-10040	D - 2	97702-60520	F - 10
	E - 13	90467-120A3	E - 13	91317-08030	D - 11	93305-20605	C - 12	95027-06008	F - 11	97706-04012	F - 4
90401-20145	B - 14	90467-14015	B - 15	91380-06014	C - 5	93306-00106	B - 9	95027-06020	F - 8		F - 7
90413-07007	D - 14	90467-14171	B - 15		C - 8		C - 14	95302-08600	E - 6	97707-50016	D - 6
90413-07023	B - 11	90467-17128	C - 4	91401-20012	E - 13	93306-00304	C - 10	95304-06700	C - 15		F - 6
90430-06014	B - 2	90467-180A0	C - 4	91401-25015	E - 11	93306-00420	E - 3	95602-05100	F - 7	98502-04012	E - 9
	B - 10	90467-18172	C - 4	91492-12010	C - 2	93306-20124	C - 7	95604-10200	D - 2	98502-05014	C - 2
90430-06166	C - 6	90467-200A0	B - 10	91702-08040	E - 11	93306-20230	C - 9	95607-04100	D - 6	98502-06012	C - 2
90430-08143	C - 7		B - 12	91808-16023	B - 2	93306-20531	E - 5	95607-05100	D - 6	98507-03016	C - 2
90430-10005	E - 9	90480-01333	D - 2	91808-30031	B - 9	93306-205A2	C - 13	95607-05200	F - 11	98507-04010	F - 8
	E - 13	90480-01559	D - 7	92012-06014	D - 8	93306-20652	C - 12	95607-06200	D - 4	98507-05022	F - 8
90430-10148	F - 9	90480-08264	B - 15	92014-08012	C - 7	93306-27208	C - 12		E - 2	98507-05030	F - 8
90445-08022	D - 7	90480-11009	F - 7	92014-08020	E - 13	93310-232R9	C - 10		F - 8	98507-05045	F - 8
90445-087K6	D - 7	90480-12003	D - 9	92017-05030	F - 11	93315-31502	C - 10	95607-10200	D - 9	98507-06008	E - 11
90445-19002	E - 10	90480-12010	B - 10	92502-06010	C - 2	93315-31758	D - 8		D - 10	98507-06020	C - 3
90445-19003	E - 12	90480-12072	D - 4	92902-04100	E - 9	93315-41762	D - 8		D - 11	98707-03016	F - 8
90446-15386	E - 13	90480-12314	D - 15	92902-04600	E - 9	93315-42536	D - 8		E - 12	98907-05008	D - 14
90450-22017	B - 12	90480-13004	D - 5	92907-05200	F - 7	93317-11096	C - 10	95612-08625	B - 2	99001-07600	C - 10
90450-32001	B - 10	90480-13010	B - 13	92907-08600	C - 10	93317-11295	C - 15	95617-06100	E - 9	99002-10600	C - 15
	B - 12	90480-13014	C - 8	92907-10200	D - 11	93317-33590	E - 5	95702-06500	C - 5	99009-10400	C - 11

NUMERICAL INDEX

PART NO.	GRID NO.	PART NO.	GRID NO.	PART NO.	GRID NO.	PART NO.	GRID NO.	PART NO.	GRID NO.
99480-10018	C - 7								
99530-08012	B - 14								
99530-10014	C - 6								
99530-10114	B - 2								
	B - 4								